

Masterflex® L/S® Pump Head Selection Guide

Description	Flow rates	Number of rollers	Multichannel or stackable	Special features
L/S Standard Pump Heads				
	0.001 to 2900 mL/min	3	Yes, stack up to 4 heads	<ul style="list-style-type: none"> ✓ Highest precision, yet economical ✓ Accurate, repeatable fluid transfer ✓ Each head dedicated to one tubing size
L/S Easy-Load® II Pump Heads				
	0.001 to 2900 mL/min	4	Yes, stack up to 4 heads	<ul style="list-style-type: none"> ✓ Easy tubing changes ✓ Automatic retention ✓ Adjustable occlusion
L/S Easy-Load® 3 Pump Heads				
	0.001 to 2900 mL/min	3	Yes, stack up to 4 heads	<ul style="list-style-type: none"> ✓ Easy tubing changes ✓ Automatic retention ✓ Same side tubing entry/exit ✓ Install and stack without tools or hardware
L/S Easy-Load® Pump Heads				
	0.001 to 2300 mL/min	3	Yes, stack up to 4 heads	<ul style="list-style-type: none"> ✓ Load or change multiple tubing sizes quickly and easily ✓ Low maintenance ✓ Models available for ATEX Zone 2 applications
L/S High-Performance Pump Heads				
	0.006 to 3400 mL/min	3	No	<ul style="list-style-type: none"> ✓ Highest flow rate of any L/S pump head ✓ Up to 150 psi (10.3 bar) with L/S HP (High-Pressure) pump tubing ✓ Model available for ATEX Zone 2 applications
L/S PTFE-Tubing Pump Heads				
	0.001 to 65 mL/min	6	No	<ul style="list-style-type: none"> ✓ Uses rigid PTFE-tubing ✓ Pressures up to 100 psi (6.9 bar) ✓ Transfer aggressive solvents ✓ High purity
L/S Multichannel Pump Heads				
	0.00005 to 2300 mL/min (per channel)	3 or 6	Yes, stack up to 32 channels	<ul style="list-style-type: none"> ✓ Synchronous flow from up to 32 channels without cartridges ✓ Two-stop tubing sets are easy to load, with no adjustment needed
L/S Multichannel Cartridge Pump Heads				
	0.00001 to 1700 mL/min (per channel)	3, 4, 6, or 8	Yes, 1 to 12 channels	<ul style="list-style-type: none"> ✓ Synchronous flow rates ✓ Run up to 12 channels on a single pump head ✓ Easy tubing changes ✓ Holds tubing securely in place
L/S PTFE-Diaphragm Pump Heads				
	10.0 to 800 mL/min	—	No	<ul style="list-style-type: none"> ✓ PTFE and borosilicate glass are the only wetted parts ✓ Up to 100 psi (6.9 bar) ✓ Accurate metering ✓ Handles aggressive fluids

L/S® STANDARD PUMP HEADS

FEATURES/BENEFITS

- ▶ Ideal for fluid transfer applications where accuracy and repeatability are important
- ▶ Tubing enters/exits on top of pump head
- ▶ Deliver flow rates from 0.06 to 2900 mL/min
- ▶ Precision molded housing and tubing cavity
- ▶ Each pump head is designed for one size of tubing—ensuring optimal occlusion and performance
- ▶ Adapts easily to OEM applications
- ▶ Interchangeable
- ▶ Stackable for multichannel pumping

SELECTION CRITERIA

1. Flow rate/tube size desired.
 2. Materials of construction.
 3. Compatibility with drives.
- See specifications for more information.

Order tubing and drives separately.

COMPATIBILITY WITH DRIVES

- ▶ Mount on all drives accepting Masterflex L/S pump heads

PUMP HOUSING SPECIFICATIONS

Clear Polycarbonate (PC)

- ▶ General-purpose applications
- ▶ Pump head operation visible through housing
- ▶ Select from CRS/Buna N or 300-series SS/PTFE shielded ball-bearing

Polyphenylene Sulfide (PPS)

- ▶ Best protection from corrosive liquids/vapors
- ▶ 300-series stainless steel shielded ball-bearing

Watch the VIDEO!

Watch video tutorial on how to load Masterflex® L/S® Standard Pump Heads. Go to...
Masterflex.com/video

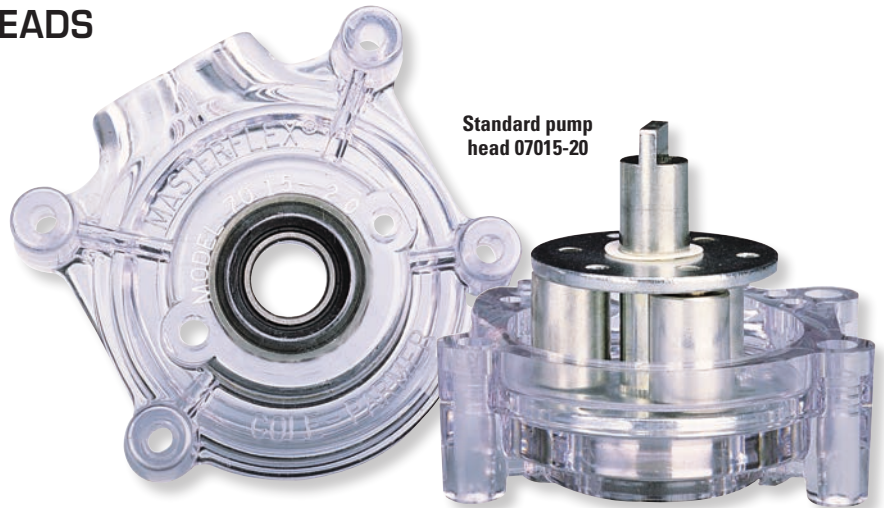

Standard pump head 07015-20

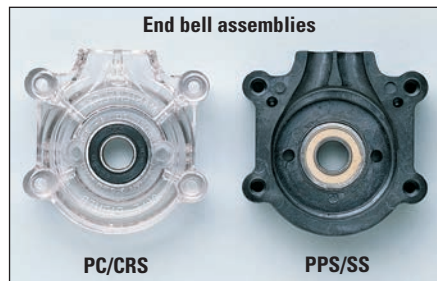

End bell assemblies

PC/CRS

PPS/SS

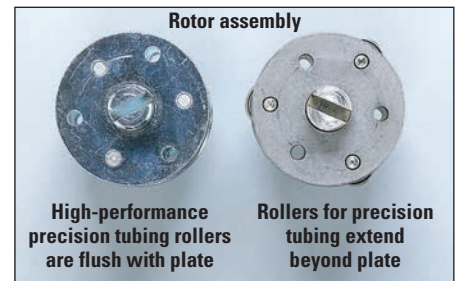

Rotor assembly

High-performance precision tubing rollers are flush with plate

Rollers for precision tubing extend beyond plate

ISO9001:2008
CERTIFIED SUPPLIER

2 year
warranty

ROLLER/ROTOR SPECIFICATIONS

Plated Cold-Rolled Steel (CRS)

- ▶ General-purpose applications
- ▶ Ball-bearing construction
- ▶ Continuous duty up to 600 rpm

300-Series Stainless Steel (SS)

- ▶ Corrosive fluids
- ▶ Shielded ball-bearing construction (highest life expectancy)
- ▶ Continuous duty up to 600 rpm

ORDERING INFORMATION

Pump tubing size	PC housing		PPS housing
	CRS rotor	SS rotor	SS rotor
For Precision tubing			
L/S 13	HL-07013-20	HL-07013-21	HL-07013-52
L/S 14	HL-07014-20	HL-07014-21	HL-07014-52
L/S 16	HL-07016-20	HL-07016-21	HL-07016-52
L/S 17	HL-07017-20	HL-07017-21	HL-07017-52
L/S 18	HL-07018-20	HL-07018-21	HL-07018-52
For High-performance Precision tubing			
L/S 15	HL-07015-20	HL-07015-21	HL-07015-52
L/S 24	HL-07024-20	HL-07024-21	HL-07024-52
L/S 35	HL-07035-20	HL-07035-21	—
L/S 36	HL-07036-30	HL-07036-31	—

PC = polycarbonate PPS = polyphenylene sulfide
CRS = cold-rolled steel SS = stainless steel

L/S PUMP TUBING FLOW RATE INFORMATION

Order Masterflex L/S pump tubing separately on pages 68–73

Tubing cross sections	L/S Precision pump tubing					L/S High-performance Precision pump tubing			
	L/S 13	L/S 14	L/S 16	L/S 17	L/S 18	L/S 15	L/S 24	L/S 35	L/S 36
Flow rate—mL/rev	0.06	0.21	0.8	2.8	3.8	1.7	2.8	3.8	4.8
mL/min @ 600 rpm	36	130	480	1700	2300	1000	1700	2300	2900
Max pressure†	2.7 bar (40 psi)			1.4 bar (20 psi)	1.0 bar (15 psi)	2.7 bar (40 psi)		2.4 bar (35 psi)	1.4 bar (20 psi)
Max vacuum†	660 mm Hg (26" Hg)			510 mm Hg (20" Hg)			660 mm Hg (26" Hg)		
Suction lift	8.8 m H ₂ O (29 ft H ₂ O)			6.7 m H ₂ O (22 ft H ₂ O)			8.8 m H ₂ O (29 ft H ₂ O)		

†Actual performance varies depending upon tubing materials—see pages 20–24 and 172–192 for more information.

Distributed by:
MASTERFLEX®
 Fiedler Scientific Instruments, s.r.o.
 info@lab-eu.com info@pristroje.cz

PUMP HEADS



SPECIFICATIONS for L/S Standard Pump Heads

Catalog number	HL-070XX-20 and -30 Series	HL-070XX-21 and -31 Series	HL-070XX-52 Series
Performance Specifications			
Flow capacity	0.001 to 2900 mL/min (0 to 46 GPH) [†]		
Max rpm	600		
Number of rollers	3		
Torque Specifications[‡] [a single head pumping water at 0 psi, 21°C (70°F)]			
Norpren [®] , PharMed [®] BPT	Starting torque	18.0 kg-cm (250 oz-in)	
	Running torque	5.8 kg-cm (80 oz-in)	
Tygon [®] , Viton [®]	Starting torque	27.7 kg-cm (385 oz-in)	
	Running torque	4.6 kg-cm (64 oz-in)	
C-FLEX [®] , Silicone	Starting torque	5.8 kg-cm (80 oz-in)	
	Running torque	2.2 kg-cm (30 oz-in)	
Physical Specifications			
Housing material	Clear polycarbonate	Polyphenylene sulfide	
Rotor material	Cold-rolled steel	Stainless steel	
Operating temperature	0 to 40°C (32 to 104°F)		
Shipping weight	0.54 kg (1.18 lb)		

[†]Depending on pump head selected.

[‡]Actual torque depends on tubing size formulation. For complete torque data, please see pages 172–192.

MULTICHANNEL CAPABILITIES

Mount up to four pump heads depending on the drive. Order hardware based on the number of pump heads to be mounted.

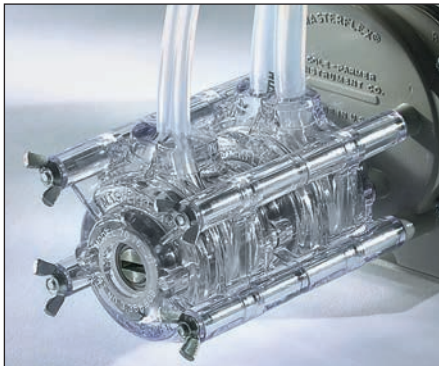

Mounting hardware

MOUNTING HARDWARE

Heads to be mounted	Catalog number/set
	Stainless steel
L/S 13 to 35 Standard pump heads	
One	HL-07013-04
Two	HL-07013-05
Three	HL-07013-08
Four	HL-07013-09
L/S 36 Standard pump head	
One	HL-07036-01
Two	HL-07036-02

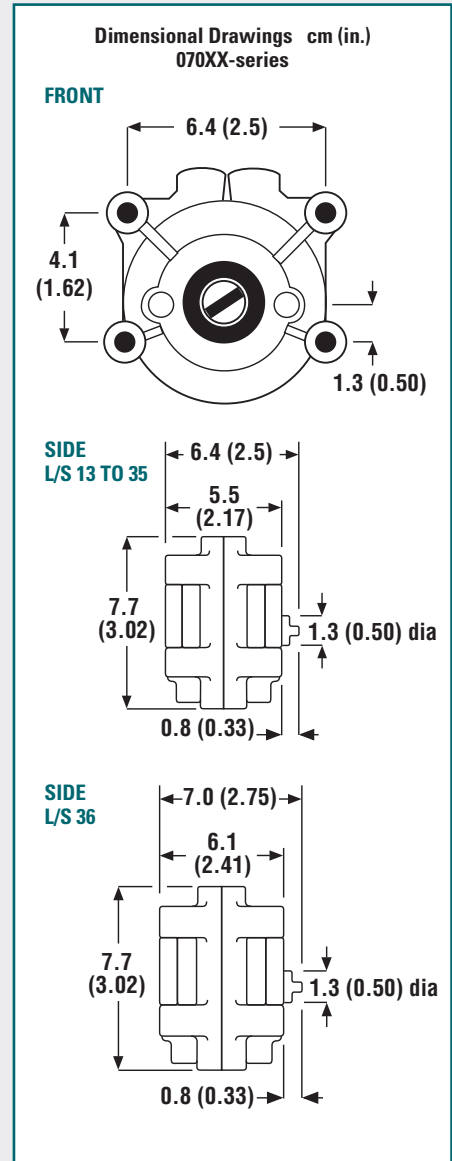

NOTES

The design of the Standard pump head enables the most precise dispensing accuracy of any Masterflex pump head.

HOW TO LOAD YOUR PUMP HEAD



1. Disassemble pump head. Load tubing.



2. Use the loading key (included) to ensure proper tubing alignment and tension.

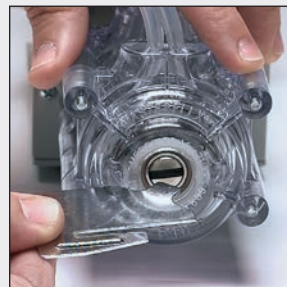

3. Reassemble two halves and mount on drive.

L/S[®] TUBING
 L/S[®] DRIVES
 L/S[®] PUMP SYSTEMS.....

ACCESSORIES.....

TECHNICAL DATA.....

L/S® EASY-LOAD® 3 PUMP HEADS

FEATURES/BENEFITS

- ▶ Deliver flow rates from 0.06 to 2900 mL/min
- ▶ Automatic tubing retention speeds tube loading and fluid changeover
- ▶ Same side tubing entry/exit for easy integration into space-limited applications
- ▶ Long occlusion surface prevents fluid backflow
- ▶ Included mounting plate adapts head to L/S drives
- ▶ Mount and operate head in any of four positions
- ▶ Locking tab secures head during operation in either direction of rotation
- ▶ Twist-lock mounting feature lets you mount and stack heads in seconds without tools or hardware
- ▶ Stackable for multiple-channel pumping and increased flow capacity
- ▶ Pump heads accept several tubing sizes

SELECTION CRITERIA

1. Flow rate/tube size desired.
2. Materials of construction (rotor).
3. Compatibility with drives.

Silicone tubing (43 cm or 17") and mounting plate/adaptor supplied.

See specifications for more information.

Order tubing and drives separately.

COMPATIBILITY WITH DRIVES

- ▶ Mount on all drives accepting Masterflex L/S pump heads

NOTES

Use only Masterflex pump tubing with Masterflex pumps to ensure optimal performance. Use of other tubing may void applicable warranties.

PUMP HOUSING SPECIFICATIONS

Polypropylene (PP)

- ▶ General-purpose applications
- ▶ Good protection from corrosive liquids/vapors
- ▶ Select from CRS/Buna N or 400-series SS/PTFE shielded ball bearing

ROLLER/ROTOR SPECIFICATIONS

Plated Cold-Rolled Steel (CRS)

- ▶ General-purpose applications
- ▶ Humidity: 0 to 90%
- ▶ Ball-bearing construction
- ▶ Continuous duty up to 600 rpm
- ▶ Precision and high-performance precision tubing versions

300-Series Stainless Steel (SS)

- ▶ Corrosive fluids
- ▶ Humidity: 0 to 90%
- ▶ PTFE shielded ball-bearing construction (highest life expectancy)
- ▶ Continuous duty up to 600 rpm
- ▶ Precision and high-performance precision tubing versions

MULTICHANNEL CAPABILITIES

- ▶ Mount up to four Easy-Load 3 pump heads on a single drive without tools or hardware



Easy-Load 3 pump head 77800-60

ISO 9001:2008 CERTIFIED SUPPLIER 2 year warranty

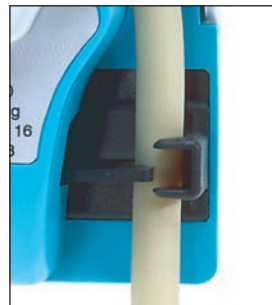

Tubing retainers automatically stretch and grip tubing when head is closed.

ORDERING INFORMATION

Pump tubing size	PP housing	
	CRS rotor	SS rotor
For Precision tubing		
L/S 13		
L/S 14		
L/S 16	HL-77800-50	HL-77800-60
L/S 25		
L/S 17		
L/S 18		
For High-performance precision tubing		
L/S 15		
L/S 24	HL-77800-52	HL-77800-62
L/S 35		
L/S 36		

PP = polypropylene CRS = cold-rolled steel
SS = stainless steel

L/S PUMP TUBING FLOW RATE INFORMATION

Order Masterflex L/S pump tubing separately on pages 68–73.

Tubing cross sections	L/S Precision pump tubing						L/S High-performance Precision pump tubing				
	L/S 13	L/S 14	L/S 16	L/S 25	L/S 17	L/S 18	L/S 15	L/S 24	L/S 35	L/S 36	
Flow rate—mL/rev	0.06	0.21	0.8	1.7	2.8	3.8	1.7	2.8	3.8	4.8	
mL/min @ 600 rpm	36	130	480	1000	1700	2300	1000	1700	2300	2900	
Max pressure†	2.7 bar (40 psi)			2.4 bar (35 psi)	1.4 bar (20 psi)	1.0 bar (15 psi)	2.0 bar (30 psi)		1.7 bar (25 psi)	1.4 bar (20 psi)	
Max vacuum†	660 mm Hg (26" Hg)				510 mm Hg (20" Hg)			660 mm Hg (26" Hg)			
Suction lift	8.8 m H ₂ O (29 ft H ₂ O)				6.7 m H ₂ O (22 ft H ₂ O)			8.8 m H ₂ O (29 ft H ₂ O)			

†Actual performance varies depending upon tubing materials—see pages 20–24 and 172–192 for more information.

Distributed by:
Fiedler Scientific Instruments, s.r.o.
info@lab-eu.com info@pristroje.cz



SPECIFICATIONS for L/S Easy-Load 3 Pump Heads

Catalog number	HL-77800-50 HL-77800-52	HL-77800-60 HL-77800-62
Performance Specifications		
Flow capacity	0.001 to 2900 mL/min (0.19 to 45.8 GPH) [†]	
Max rpm	600	
Number of rollers	3	
Torque Specifications [a single head pumping water at 0 psi, 21.1°C (70°F)][‡]		
Norprene®, PharMed® BPT	Starting torque	9.4 kg-cm (130 oz-in)
	Running torque	2.2 kg-cm (30 oz-in)
Tygon®, Viton®	Starting torque	15.8 kg-cm (220 oz-in)
	Running torque	3.6 kg-cm (50 oz-in)
C-FLEX®, Silicone	Starting torque	4.7 kg-cm (65 oz-in)
	Running torque	2.9 kg-cm (40 oz-in)
Physical Specifications		
Housing material	Polypropylene	
Rotor material	Cold-rolled steel	Stainless steel
Operating temperature	0 to 40°C (32 to 104°F)	
Shipping weight	0.9 kg (1.9 lb)	

[†]Depending on pump head and tubing selected. [‡]Maximum torque depends on tubing size.

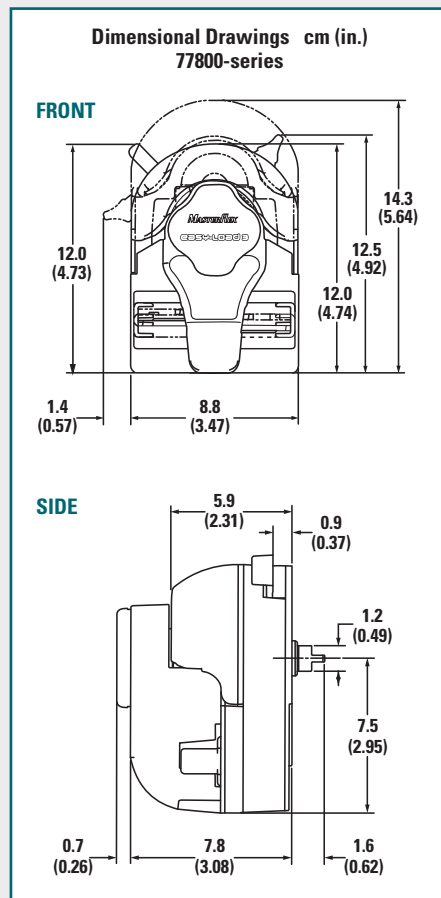

Mounting Your Pump Head



Attach mounting plate to your L/S drive.



Twist and lock Easy-Load 3 pump head onto mounting plate.

Stacking Your Pump Head



For multiple-channel applications, simply remove the front cover and . . .



Stack pump heads up to the limits of your drive.

HOW TO LOAD YOUR PUMP HEAD



1. With head on drive, rotate activator lever counter-clockwise to open occlusion bed and tubing retainers.



2. Place tubing over rollers and through retainers.



3. Rotate activator lever clockwise to close occlusion bed and retainers.

FREE TUBING TEST KIT!

Can't find your chemical in the tables?

Request your FREE tubing kit to test compatibility of your chemicals against different tubing formulations. Request item HL-00101-10.

Call or go online to request your FREE test kit today!



L/S® EASY-LOAD® II PUMP HEADS

FEATURES/BENEFITS

- ▶ Deliver flow rates from 0.001 to 2900 mL/min
- ▶ Four-roller design improves pressure performance, stability, and reduces pulsation
- ▶ Improved occlusion bed geometry reduces tubing wear, lengthens tubing life
- ▶ Over-center cam for quick tubing changes
- ▶ Adjustable and fixed occlusion available
- ▶ Adapts easily to OEM applications
- ▶ Stackable for multichannel pumping
- ▶ Automatic tubing retention eliminates manual adjustments
- ▶ Pump head accepts several tubing sizes

SELECTION CRITERIA

1. Flow rate/tube size desired.
 2. Materials of construction (rotor).
 3. Compatibility with drives.
 4. Adjustable or fixed occlusion.
- ▶ 38 cm (15") of silicone tubing and single-channel mounting hardware supplied.
- See specifications for more information.

Order tubing and drives separately.

COMPATIBILITY WITH DRIVES

- ▶ Mount on most drives accepting Masterflex L/S pump heads

PUMP HOUSING SPECIFICATIONS

Polyphenylene Sulfide (PPS)

- ▶ Best protection from corrosive liquids/vapors
- ▶ Nylon tubing retainers
- ▶ Select from CRS/Buna N or 400-series SS/PTFE shielded ball-bearing

FIXED/ADJUSTABLE OCCLUSION

Fixed Occlusion

- ▶ High flow rates at an economical price
- ▶ Factory calibrated for nominal occlusion

Adjustable Occlusion

- ▶ Increase occlusion to maximize pressure performance and obtain better suction lift
- ▶ Reduce occlusion to extend tubing life

ROLLER/ROTOR SPECIFICATIONS

Plated Cold-Rolled Steel (CRS)

- ▶ General-purpose applications
- ▶ Humidity: 0 to 90%
- ▶ Ball-bearing construction
- ▶ Continuous duty up to 600 rpm
- ▶ Precision and High-performance precision tubing versions

300-Series Stainless Steel (SS)

- ▶ Corrosive fluids
- ▶ Humidity: 0% to 90%
- ▶ PTFE shielded ball-bearing (highest life expectancy)
- ▶ Continuous duty up to 600 rpm
- ▶ Precision and High-performance precision tubing versions

MULTICHANNEL CAPABILITIES

- ▶ Mount up to four Easy-Load II pump heads on a single drive
- ▶ Order hardware depending on number of pump heads to be mounted

ISO 9001:2008
CERTIFIED SUPPLIER

2 year
warranty

ORDERING INFORMATION

Pump tubing size	Fixed occlusion		Adjustable occlusion
	CRS rotor	SS rotor	
For Precision tubing			
L/S 13			
L/S 14			
L/S 16	HL-77200-50	HL-77200-60	HL-77201-60
L/S 25			
L/S 17			
L/S 18			
For High-performance precision tubing			
L/S 15			
L/S 24	HL-77200-52	HL-77200-62	HL-77201-62
L/S 35			
L/S 36			

CRS = cold-rolled steel SS = stainless steel

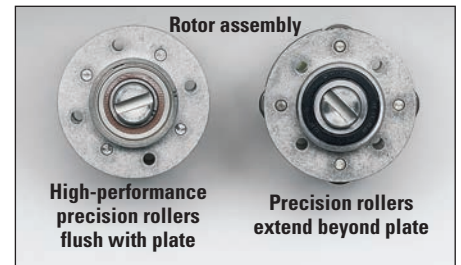
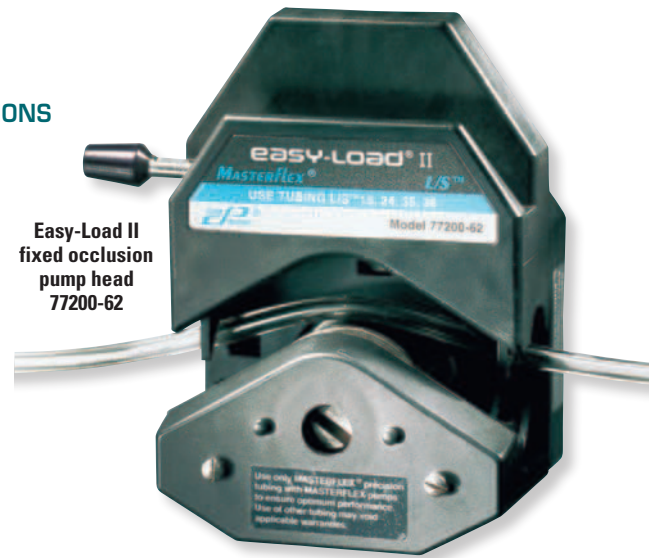

MOUNTING HARDWARE

Heads to be mounted	Catalog number/set
	Stainless steel
One	HL-77200-01
Two	HL-77200-02
Three	HL-77200-03
Four	HL-77200-04

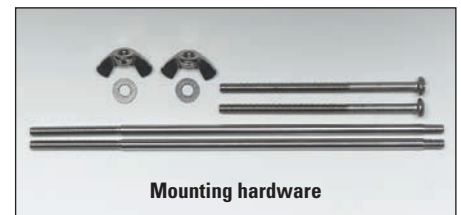

L/S PUMP TUBING FLOW RATE INFORMATION

Order Masterflex L/S pump tubing separately on pages 68–73.

Tubing cross sections	L/S Precision pump tubing						L/S High-performance Precision pump tubing			
	L/S 13	L/S 14	L/S 16	L/S 25	L/S 17	L/S 18	L/S 15	L/S 24	L/S 35	L/S 36
Flow rate—mL/rev	0.06	0.21	0.8	1.7	2.8	3.8	1.7	2.8	3.8	4.8
mL/min @ 600 rpm	36	130	480	1000	1700	2300	1000	1700	2300	2900
Max pressure†	2.7 bar (40 psi)			2.4 bar (35 psi)	1.4 bar (20 psi)	1.0 bar (15 psi)	2.7 bar (40 psi)		2.4 bar (35 psi)	1.4 bar (20 psi)
Max vacuum†	660 mm Hg (26" Hg)				510 mm Hg (20" Hg)		660 mm Hg (26" Hg)			
Suction lift	8.8 m H ₂ O (29 ft H ₂ O)				6.7 m H ₂ O (22 ft H ₂ O)		8.8 m H ₂ O (29 ft H ₂ O)			

†Actual performance varies depending upon tubing materials—see pages 20–24 and 172–192 for more information.

Distributed by:
Fiedler Scientific Instruments, s.r.o.
info@lab-eu.com info@pristroje.cz

SPECIFICATIONS for L/S Easy-Load II Pump Heads

Catalog number	HL-77200-50 HL-77200-52	HL-77200-60 HL-77200-62	HL-77201-60 HL-77201-62
Performance Specifications			
Flow capacity	0.001 to 2900 mL/min (9.48 to 45.82 GPH) ¹		
Max rpm	600		
Number of rollers	4		
Torque Specifications² [a single head pumping water at 0 psi, 21°C (70°F)]			
Norprene [®] , PharMed [®] BPT	Starting torque	12.9 kg-cm (180 oz-in)	
	Running torque	3.6 kg-cm (50 oz-in)	
Tygon [®] , Viton [®]	Starting torque	21.2 kg-cm (295 oz-in)	
	Running torque	4.3 kg-cm (60 oz-in)	
C-FLEX [®] , Silicone	Starting torque	5.8 kg-cm (80 oz-in)	
	Running torque	2.2 kg-cm (30 oz-in)	
Physical Specifications			
Housing material	Polyphenylene sulfide		
Rotor material	Cold-rolled steel	Stainless steel	
Operating temperature	0 to 40°C (32 to 104°F)		
Shipping weight	0.9 kg (1.9 lb)		

¹Depending on pump head and tubing selected.

²Maximum torque depends on tubing size. For complete torque data, see pages 172–192.

Dimensional Drawings cm (in.) 77200-series, 77201-series, and 77202-series

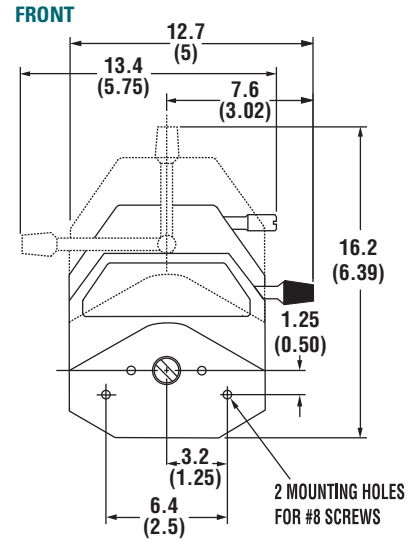

SIDE

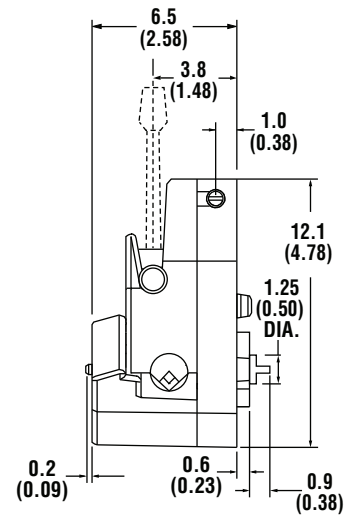

L/S EASY-LOAD II TWO-CHANNEL PUMP HEADS

Identical to our Easy-Load II pump heads—except with two flow channels. Pump two channels simultaneously from one head (you must use the same size tubing in each channel), eliminating the need to stack heads. Each pump head accepts L/S 13, L/S 14, L/S 16, and L/S 25 tubing sizes in any formulation. Mount up to four two-channel pump heads on a single drive.

ORDERING INFORMATION

Pump tubing size	mL per rev	Flow rates in mL/min at noted rpm (per channel)		Fixed occlusion	
		1 to 100	6 to 600	CRS rotor	SS rotor
L/S 13	0.06	0.06 to 6	0.36 to 36		
L/S 14	0.21	0.21 to 21	1.3 to 130	HL-77202-50	HL-77202-60
L/S 16	0.8	0.8 to 80	4.8 to 480		
L/S 25	1.7	1.7 to 170	10 to 1000		

CRS = cold-rolled steel SS = stainless steel



HOW TO LOAD YOUR PUMP HEAD



1. Rotate lever to left to open pump head. Load the correct size tubing.



2. Move lever to the right to close pump head.



3. Tubing is retained by automatic tubing retention on all models.



3. Adjustable occlusion available on 77201-60 and -62 models.

NOTES

Use only Masterflex pump tubing with Masterflex pumps to ensure optimal performance. Use of other tubing may void applicable warranties.

L/S[®] TUBING
L/S[®] DRIVES
L/S[®] PUMP SYSTEMS.....

ACCESSORIES.....

TECHNICAL DATA.....

L/S® EASY-LOAD® PUMP HEADS

FEATURES/BENEFITS

- Over-center cam design for fast tubing changes
- Deliver flow rates from 0.001 to 2300 mL/min
- Proprietary design and adjustable tubing retention feature
- Fixed occlusion for good flow repeatability
- Adapts easily to OEM applications
- Interchangeable
- Multichannel pumping
- Accepts several tubing sizes
- Models 07518-40 and 07518-42 are ATEX Zone 2 rated EEx II 3 G c IIC T6; NEC rated for Class I Division 2 Groups A, B, C, D T6

SELECTION CRITERIA

- Flow rate desired.
 - Tubing size needed.
 - Materials of construction (housing, rotor).
 - Compatibility with drives.
- 38 cm (15") of silicone tubing and single-channel mounting hardware are supplied
- See specifications for more information.

Order tubing and drives separately.

COMPATIBILITY WITH DRIVES

- Mount on all drives accepting Masterflex L/S pump heads

PUMP HOUSING SPECIFICATIONS

Polysulfone (PSF)

- General-purpose applications
- Select from CRS or 300-series SS/PTFE shielded ball-bearing

Polyphenylene Sulfide (PPS)

- Best protection from corrosive liquids/vapors
- 300-series SS/PTFE shielded ball-bearing



Pump head 07518-00 with polysulfone housing



Pump head 07518-60 with polyphenylene sulfide housing

ROLLER/ROTOR SPECIFICATIONS

Plated Cold-Rolled Steel (CRS)

- General-purpose applications
- Continuous duty up to 600 rpm
- Precision and High-performance precision versions

300-Series Stainless Steel (SS)

- Corrosive fluids
- PTFE shielded ball-bearing (highest life expectancy)
- Continuous duty up to 600 rpm
- Precision and High-performance precision versions

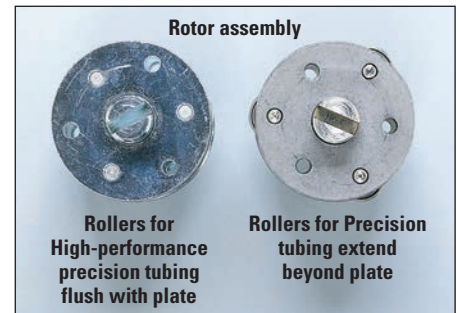

Rotor assembly



Rollers for High-performance precision tubing flush with plate



Rollers for Precision tubing extend beyond plate

ISO9001:2008
CERTIFIED SUPPLIER

2 year
warranty

ATEX
Zone 2
07518-40, -42

ORDERING INFORMATION

Pump tubing size	PSF housing		PPS housing	ATEX-approved PSF housing
	CRS rotor	SS rotor	SS rotor	SS rotor

For Precision tubing

L/S 13				
L/S 14				
L/S 16	HL-07518-00	HL-07518-10	HL-07518-60	HL-07518-40
L/S 25				
L/S 17				
L/S 18				

For High-performance precision tubing

L/S 15	HL-07518-02	HL-07518-12	HL-07518-62	HL-07518-42
L/S 24				

PSF = polysulfone PPS = polyphenylene sulfide
CRS = cold-rolled steel SS = stainless steel

DISCONTINUED - NEW MODELS AVAILABLE

L/S PUMP TUBING FLOW RATE INFORMATION

Order Masterflex L/S pump tubing separately on pages 68–73.

Tubing cross sections	L/S Precision pump tubing						L/S High performance Precision pump tubing	
	L/S 13	L/S 14	L/S 16	L/S 25	L/S 17	L/S 18	L/S 15	L/S 24
Flow rate—mL/rev	0.06	0.21	0.8	1.92	2.8	3.8	1.7	2.8
mL/min @ 600 rpm	36	130	480	1150	1700	2300	1000	1700
Max pressure [†]	2.7 bar (40 psi)			2.4 bar (35 psi)	1.4 bar (20 psi)	1.0 bar (15 psi)	2.7 bar (40 psi)	
Max vacuum [†]	610 mm Hg (24" Hg)							
Suction lift	8.2 m H ₂ O (26.8 ft H ₂ O)							

[†]Actual performance varies depending upon tubing materials—see pages 20–24 and 172–192 for more information.

Distributed by:
Fiedler Scientific Instruments, s.r.o.
info@lab-eu.com info@pristroje.cz



SPECIFICATIONS for L/S Easy-Load Pump Heads

Catalog number	HL-07518-00 HL-07518-02	HL-07518-10 HL-07518-12 HL-07518-40 HL-07518-42	HL-07518-60 HL-07518-62
----------------	--	--	--

Performance Specifications	
Flow capacity	0.001 to 2300 mL/min (0 to 36 GPH)*
Max rpm	600
Number of rollers	3
Torque Specifications† [a single pump head pumping water at 0 psi, 21°C (70°F)]	
Norprene®, Pharmed® BPT	Starting torque 8.6 kg-cm (120 oz-in) Running torque 1.5 kg-cm (21 oz-in)
Tygon®, Viton®	Starting torque 13.0 kg-cm (180 oz-in) Running torque 2.5 kg-cm (35 oz-in)
C-FLEX®, Silicone	Starting torque 5.0 kg-cm (70 oz-in) Running torque 1.0 kg-cm (14 oz-in)
Physical Specifications	
Housing material	Polysulfone Polyphenylene sulfide
Rotor material	Cold-rolled steel Stainless steel
Operating temperature	0 to 40°C (32 to 104°F)
Shipping weight	0.9 kg (1.9 lb)

*Depending on pump head selected.

†Actual torque depends on tubing size and formulation. For complete torque data, please see pages 172–192.

MULTICHANNEL CAPABILITIES

- Mount up to four Easy-Load pump heads on a single drive depending on drive specifications.
- Order hardware based on number of pump heads to be mounted.

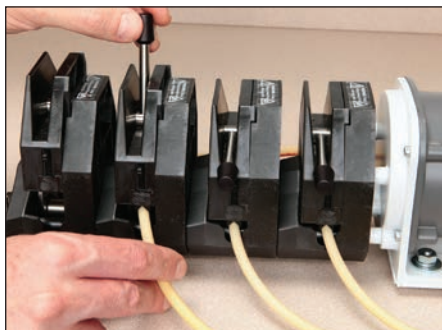

With single or multiple channels, you can change tubing in each channel without removing the Easy-Load pump head(s) from your drive.

MOUNTING HARDWARE

Heads to be mounted	Catalog number/set Stainless steel
One	HL-07013-04
Two	HL-07013-05
Three	HL-07013-08
Four	HL-07013-09



Mounting hardware
07013-04 (one) and 07013-05 (two channel)

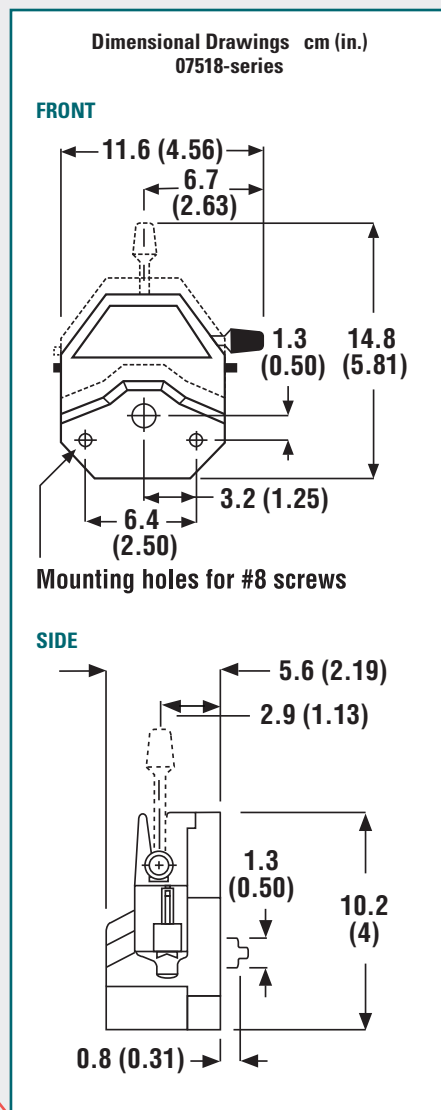

NOTES

Use only Masterflex pump tubing with Masterflex pumps to ensure optimal performance. Use of other tubing may void applicable warranties.

HOW TO LOAD YOUR PUMP HEAD



1. Rotate lever to left to open head. Load tubing.



2. Close head. Adjust side tubing retainers to hold tubing.

L/S® TUBING
L/S® DRIVES
L/S® PUMP SYSTEMS.....

ACCESSORIES.....

TECHNICAL DATA.....

MASTERFLEX®

L/S®

New Masterflex® L/S® Easy-Load® Pump Heads

Ideal for many
applications from
laboratory, to medical
devices, to industrial

- Sleek, modern design perfect for clinical and biopharmaceutical applications
- Smaller footprint fits into almost any space
- Reduced pulsation and improved pressure capabilities with new four-roller design
- Improved occlusion bed geometry reduces tubing wear, lengthens tubing life
- Faster tube changes with single-thumb actuation and automatic tubing retention
- Stack the pump heads for multichannel pumping

The new Masterflex L/S Easy-Load pump head replaces the original Easy-Load pump head launched back in 1989. This new pump head not only has a new sleek and compact design but also has features that provide more efficient pumping. The four-roller design improves pressure performance, stability, and reduces pulsation. Improved occlusion-bed geometry reduces tubing wear and lengthens tubing life. Tubing changes have never been faster with single-thumb actuation.

The Easy-Load pump head is ideal for many applications including challenging environments with its polyarylamide housing that protects against corrosive liquids and vapors, a corrosion-resistant stainless steel rotor, and PTFE-shielded bearings for long life expectancy.



Customizable Contact us for more options

- Mounting adapters
- Leak detection
- Motors
- Colors
- Open-head sensors
- And more...



Distributed by:
Fiedler Scientific Instruments, s.r.o.
info@lab-eu.com info@pristroje.cz

Masterflex.com

1-800-637-3739

Applications

- Bioreactors
- Angioscopy
- Seed coating
- Ablation
- Vending machines
- Surgical irrigation
- Laser cooling
- Analyzers
- Liposuction
- Fermenters
- Endoscopy
- Ice cream flavoring

Tubing cross sections	L/S Precision pump tubing						L/S High-Performance Precision pump tubing	
	L/S 13	L/S 14	L/S 16	L/S 25	L/S 17	L/S 18	L/S 15	L/S 24
Flow rate–mL/rev	0.06	0.21	0.8	1.7	2.8	3.8	1.7	2.8
mL/min @ 600 rpm	36	130	480	1000	1700	2300	1000	1700
Max pressure	2.7 bar (40 psi)			2.4 bar (35 psi)	1.4 bar (20 psi)	1.0 bar (15 psi)	2.7 bar (40 psi)	
Max vacuum	660 mm Hg (26" Hg)				510 mm Hg (20" Hg)		660 mm Hg (26" Hg)	
Suction lift	8.8 m H ₂ O (29 ft H ₂ O)				6.7 m H ₂ O (22 ft H ₂ O)		8.8 m H ₂ O (29 ft H ₂ O)	

Specifications

- Housing: polyarylamide
- Rotor: stainless steel
- Humidity: 0 to 90%

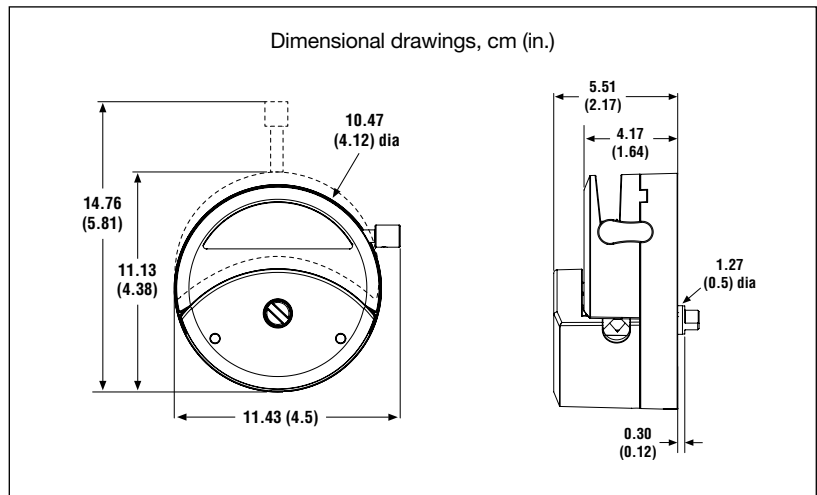

Pump tubing sizes accepted	mL per rev	Flow rates in mL/min @ 600 rpm	Maximum continuous pressure*	Maximum vacuum Hg	Maximum suction lift	Catalog number	
						Pump head	Pump head with open-head sensor
L/S Easy-Load® pump heads for Precision pump tubing (four rollers)							
L/S 13	0.06	36	40 psi (2.7 bar)	26" (660 mm)	29 ft (8.8 m)	MK-07514-10	MK-07514-30
L/S 14	0.21	130					
L/S 16	0.08	480					
L/S 25	1.7	1000	35 psi (2.4 bar)	20" (510 mm)	22 ft (6.7 m)	MK-07514-10	MK-07514-30
L/S 17	2.8	1700	20 psi (1.4 bar)				
L/S 18	3.8	2300	15 psi (1.0 bar)				
L/S Easy-Load® pump head for Precision pump tubing (six rollers)							
L/S 13	0.06	36	40 psi (2.7 bar)	24" (610 mm)	27 ft (8.2 m)	MK-07514-40	—
L/S 14	0.21	126					
L/S 16	0.75	450					
L/S 25	1.5	900	35 psi (2.4 bar)				
L/S Easy-Load® pump head for High-Performance Precision pump tubing (four rollers)							
L/S 15	1.7	1000	40 psi (2.7 bar)	26" (660 mm)	29 ft (8.8 m)	MK-07514-12	MK-07514-32
L/S 24	2.8	1700					

*Actual performance varies depending on pump tubing formulation; values shown are for firm pump tubing.

WARNING: This product can expose you to chemicals including BPA, lead, and phthalates, which is known to the State of California to cause cancer and reproductive harm. For more information, visit www.P65Warnings.ca.gov

Distributed by:
Fiedler Scientific Instruments, s.r.o.
info@lab-eu.com info@pristroje.cz

1-800-637-3739 | 1-847-381-7050

Masterflex.com

L/S® HIGH-PERFORMANCE PUMP HEADS

FEATURES/BENEFITS

- Delivers the highest flow rate of any L/S pump head
- Flow rates from 0.006 to 3400 mL/min
- To fit application needs, pump head can be mounted upright or on its side
- Tubing enters/exits same side of pump head
- Adjustable tubing retention holds tubing firmly in place
- Ideal for viscous fluid transfer
- Adapts easily to OEM applications
- Model 77250-82 is ATEX Zone 2 rated EEx II 3 G c IIC T6; NEC rated for Class I Division 2 Groups A, B, C, D T6

SELECTION CRITERIA

- Flow rate/tube size desired.
 - Materials of construction.
 - Compatibility with drives.
- 38 cm (15") of E-LFL tubing and mounting hardware are supplied

See specifications for more information.

Order tubing and drives separately.

COMPATIBILITY WITH DRIVES

- Compatible with all Masterflex L/S drives that accept two or more pump heads

PUMP HOUSING SPECIFICATIONS

- Rollers, bearings, rotor plates, and rotor shaft are made of stainless steel
- Occlusion bed: polyphenylene sulfide
- Retainer adjusting knob: polypropylene
- Main body: polyester

ROLLER/ROTOR SPECIFICATIONS

Stainless Steel (SS)

- Operating temperatures from 0 to 40°C (32 to 104°F)
- Storage temperature range: -40 to 60°C (-40 to 140°F)
- Humidity: 95% maximum, 5% minimum (noncondensing)
- Continuous duty up to 600 rpm



High-performance pump head 77250-62



High-performance pump head 77250-62 shown mounted on an L/S modular drive 07557-00

MULTICHANNEL CAPABILITIES

- L/S High-Performance pump heads are not designed to be stacked

SEE PAGE 117

For Masterflex 100 psi high-pressure pump system.

ISO9001:2008 CERTIFIED SUPPLIER

2 year warranty

ATEX Zone 2 77250-82

ORDERING INFORMATION

Pump tubing size	High-Performance pump head	ATEX-approved High-Performance pump head
L/S 15 L/S 24 L/S 35 L/S 36	HL-77250-62	HL-77250-82
L/S 14HP L/S 16HP L/S 15HP L/S 24HP		

L/S PUMP TUBING FLOW RATE INFORMATION

Order Masterflex L/S pump tubing separately on pages 68–73; order high-pressure tubing on facing page.

Tubing cross sections	L/S High-performance Precision pump tubing				L/S High-pressure Precision pump tubing			
	L/S 15	L/S 24	L/S 35	L/S 36	L/S 14HP	L/S 16HP	L/S 15HP	L/S 24HP
Flow rate—mL/rev	1.8	3.0	4.3	5.8	0.3	0.9	1.7	2.4
mL/min @ 100 rpm	180	300	430	580	30	90	170	240
mL/min @ 600 rpm	1100	1800	2600	3400	Not recommended		Not recommended	
Max pressure†	2.7 bar (40 psi)		2.4 bar (35 psi)	1.4 bar (20 psi)	10.2 bar (150 psi)	8.5 bar (125 psi)	6.8 bar (100 psi)	5.5 bar (80 psi)
Max vacuum†	660 mm Hg (26" Hg)			610 mm Hg (24" Hg)	660 mm Hg (26" Hg)			
Suction lift	8.8 m H ₂ O (29 ft H ₂ O)			8.3 m H ₂ O (27 ft H ₂ O)	8.8 m H ₂ O (29 ft H ₂ O)			

†Actual performance varies depending upon tubing materials—see pages 20–24 and 172–192 for more information.

DISCONTINUED - NEW MODELS AVAILABLE

SPECIFICATIONS for L/S High-Performance Pump Heads

Catalog number	HL-77250-62 , HL-77250-82	
Performance Specifications		
Flow capacity	0.006 to 3400 mL/min (0 to 54 GPH)	
Max rpm	600	
Number of rollers	3	
Torque Specifications [pumping water at 0 psi, 21°C (70°F)][†]		
Norprene®, PharMed® BPT	Starting torque	13.8 kg-cm (192 oz-in)
	Running torque	3.6 kg-cm (50 oz-in)
Tygon®, Viton®	Starting torque	11.5 kg-cm (160 oz-in)
	Running torque	5.4 kg-cm (75 oz-in)
C-FLEX®, Silicone	Starting torque	5.4 kg-cm (75 oz-in)
	Running torque	2.7 kg-cm (37 oz-in)
Norprene® HP, PharMed® BPT HP	Starting torque	43.9 kg-cm (610 oz-in)
	Running torque	7.2 kg-cm (100 oz-in)
Physical Specifications		
Roller, bearings, rotor plates, and rotor shaft materials	Stainless steel	
Operating temperature	0 to 40°C (32 to 104°F)	
Shipping weight	1.6 kg (3.5 lb)	

[†]For L/S 36 tubing.

ACCESSORIES

[HL-77250-01](#) Replacement mounting hardware, stainless steel.



NOTES

Use only Masterflex pump tubing with Masterflex pumps to ensure optimal performance. Use of other tubing may void applicable warranties.

ORDERING INFORMATION for L/S High-Pressure Pump Tubing

Tubing size	Catalog number	Tubing ID	Flow range (1 to 100 rpm)	Maximum pressure (continuous)	Length/pk
PharMed BPT					
L/S 14HP	HL-95664-14	1/16"	0.3 to 30 mL/min	10.2 bar (150 psi)	7.6 m (25 ft)
L/S 16HP	HL-95664-16	1/8"	0.9 to 90 mL/min	8.5 bar (125 psi)	
L/S 15HP	HL-95664-15	3/16"	1.7 to 170 mL/min	6.8 bar (100 psi)	
L/S 24HP	HL-95664-24	1/4"	2.4 to 240 mL/min	5.5 bar (80 psi)	
Norprene					
L/S 16HP	HL-06504-16	1/8"	0.9 to 90 mL/min	8.5 bar (125 psig)	7.6 m (25 ft)
L/S 15HP	HL-06504-15	3/16"	1.7 to 170 mL/min	6.8 bar (100 psig)	

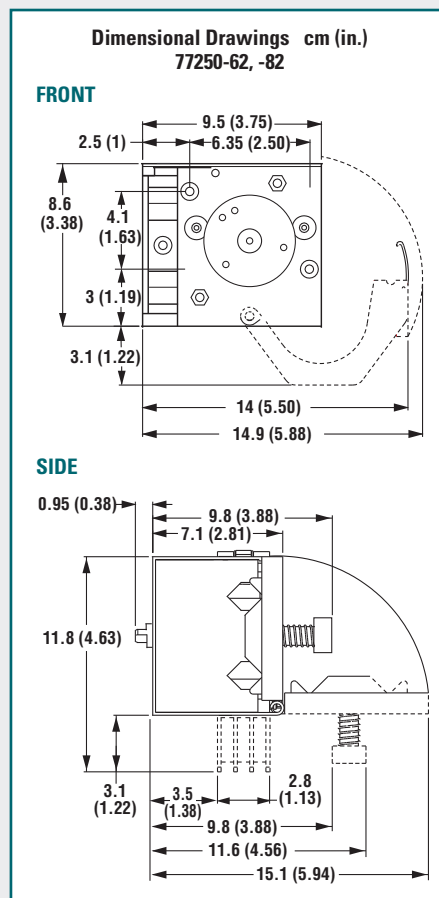

HOW TO LOAD YOUR PUMP HEAD



1. Rotate tubing retainer knob counterclockwise to release retainer, then open cover. Lift latch to open occlusion bed.

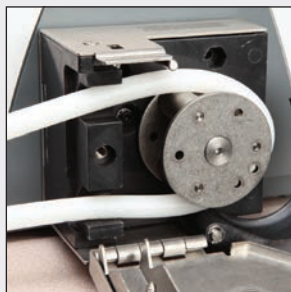

2. Insert tubing into occlusion bed, so that the tubing ends extend out of the tubing entrance and exit as shown.



3. Press occlusion bed against tubing and snap latch closed. Pull the tubing snug around rotor, close cover, and rotate tubing retainer knob clockwise. Tighten tubing retainer knob to secure tubing.

FREE TUBING TEST KIT!

Can't find your chemical in the tables?

Request your FREE tubing kit to test compatibility of your chemicals against different tubing formulations. Request item HL-00101-10.

Call or go online to request your FREE test kit today!



L/S® TUBING
L/S® DRIVES
L/S® PUMP SYSTEMS.....

ACCESSORIES.....

TECHNICAL DATA.....

L/S® High-Performance Pump Heads

All-new design offers faster tubing changes and improved ergonomics

- Simply close the pump head and tubing occlusion is optimal and automatic
- Flow rates up to 3400 mL/min with L/S high-performance precision tubing
- Reinforced nylon housing and occlusion bed with stainless steel rotor/roller assembly
- Models with open-head interlock sensor stop drive motor when pump head is open (when used with sensor-equipped drives)
- Compatible with all L/S drives that accept two or more pump heads

FEATURES

- ✓ Pressures up to 150 psi with L/S high-pressure (HP) pump tubing
- ✓ Automatic tubing occlusion—no need to adjust
- ✓ ATEX Zone 2 rated models available

MASTERFLEX®



What's included: mounting hardware and 15" (38 cm) of pump tubing.

ISO9001:2008
CERTIFIED SUPPLIER

ATEX
Zone 2
77252-80, 82



Pump tubing size	mL per rev	Flow rates in mL/min		Max system pressure psi (bar)	Catalog number		
		0.02 to 100 rpm	0.1 to 600 rpm		High-Performance pump head with open-head sensor	High-Performance pump head	ATEX-approved High-Performance pump head
High-performance pump heads for Precision pump tubing							
L/S 16	0.9	0.018 to 90	0.09 to 614	40 (2.7)	77252-60	77252-70	77252-80
L/S 25	1.9	0.038 to 187	0.19 to 1278	40 (2.7)			
L/S 17	3.0	0.06 to 307	0.30 to 1883	20 (1.4)			
L/S 18	3.8	0.076 to 377	0.38 to 2812	40 (2.7)			
High-performance pump heads for High-Performance Precision pump tubing							
L/S 14HP†	0.3	0.006 to 30	Not recommended	150 (10.3)	77252-62	77252-72	77252-82
L/S 16HP†	0.9	0.018 to 90	Not recommended	125 (8.5)			
L/S 15HP†	1.7	0.034 to 170	Not recommended	100 (6.8)			
L/S 24HP†	2.4	0.048 to 240	Not recommended	80 (5.5)			
L/S 15	1.8	0.036 to 180	0.18 to 1100	40 (2.7)			
L/S 24	3.0	0.06 to 300	0.30 to 1800	40 (2.7)			
L/S 35	4.3	0.086 to 430	0.43 to 2600	35 (2.4)			
L/S 36	5.8	0.116 to 580	0.58 to 3400	20 (1.4)			
Price							

†L/S 14HP, L/S 15HP, L/S 16HP and L/S 24HP pump tubing is for use only with the L/S High-Performance pump head mounted on any L/S 100 rpm drive capable of running two or more pump heads. **Note:** High-Performance pump heads are not stackable.

Distributed by:
Fiedler Scientific Instruments, s.r.o.
info@lab-eu.com info@pristroje.cz

Masterflex® L/S® Cytoflow™ Pump Heads



Ensure maximum protection of live cells and shear-sensitive fluids

- Convex-roller design is gentler on live cells and shear-sensitive fluids—validated by independent test data
- Large-diameter rotor delivers higher flow rates at lower speeds; no need to disrupt flow paths with "Y" assemblies
- Low-speed pumping maintains consistency and characteristics of shear-sensitive fluids
- 2- and 3-roller configurations—higher flow rates with 2 rollers, less pulsation with 3 rollers
- Compatible with all Masterflex L/S drives that accept two or more pump heads

When it comes to providing maximum protection to live cells and sensitive fluids not all peristaltic pumps are designed equally. The Masterflex L/S Cytoflow pump head was specifically designed to minimize the impact on live cells and shear-sensitive fluids.

The Cytoflow pump head has an extra-large tubing bed and fewer rollers, resulting in high flow rates at low motor speeds. In addition, the convex roller design furthers its cell viability advantages. This combination makes the Cytoflow pump head the best choice for biopharma and microbiology applications where pump operators want to minimize the impact on live cells and shear-sensitive fluids.

Distributed by:
Fiedler Scientific Instruments, s.r.o.
info@lab-eu.com info@pristroje.cz



Cytoflow 2-Roller Pump Heads



Pump tubing size	mL per rev	Flow rates in mL/min		Max system pressure psi (bar)	Catalog number
		0.02 to 100 rpm	0.1 to 600 rpm		
For Precision pump tubing					
L/S 16	1.7	0.03 to 170	0.17 to 1000	22 (1.5)	MK-77253-00
L/S 25	3.9	0.08 to 390	0.39 to 2300	22 (1.5)	
L/S 17	6.1	0.12 to 600	0.61 to 3600	22 (1.5)	
L/S 18	8.6	0.17 to 850	0.86 to 5100	22 (1.5)	
For High-Performance Precision pump tubing					
L/S 15	4.0	0.08 to 390	0.40 to 2300	22 (1.5)	MK-77253-02
L/S 24	6.2	0.12 to 600	0.62 to 3700	22 (1.5)	
L/S 35	9.5	0.19 to 930	0.95 to 5600	22 (1.5)	
L/S 36	12.8	0.26 to 1270	1.3 to 7600	22 (1.5)	



Cytoflow 3-Roller Pump Heads



Pump tubing size	mL per rev	Flow rates in mL/min		Max system pressure psi (bar)	Catalog number
		0.02 to 100 rpm	0.1 to 600 rpm		
For Precision pump tubing					
L/S 16	1.6	0.03 to 160	0.16 to 980	22 (1.5)	MK-77253-10
L/S 25	3.5	0.07 to 340	0.35 to 2000	22 (1.5)	
L/S 17	5.6	0.11 to 550	0.56 to 3300	22 (1.5)	
L/S 18	7.7	0.15 to 770	0.77 to 4600	22 (1.5)	
For High-Performance Precision pump tubing					
L/S 15	3.5	0.07 to 340	0.35 to 2000	22 (1.5)	MK-77253-12
L/S 24	5.7	0.11 to 570	0.57 to 3400	22 (1.5)	
L/S 35	7.8	0.16 to 780	0.78 to 4600	22 (1.5)	
L/S 36	9.6	0.19 to 950	0.96 to 5700	22 (1.5)	

Cell Viability Test Data

Hemolysis of blood cells was used to evaluate the sensitivity of several pump designs for live cell circulation. In vitro testing was completed using citrated bovine blood circulated through several peristaltic pump systems and settings to establish optimal conditions. Each pump system was evaluated against its Average Hemolytic Index for 180 minutes.

Factors Affecting Shear Sensitivity

Pump Motor Speed

Flow rates in peristaltic pumps are dictated by the rotation speed of the motor, measured in revolutions per minute (rpm). Peristaltic pumps generally present linear flow rates versus rpm with the tubing diameter, number of rollers, and overall occlusion bed size affecting the amount of flow per revolution. Chart 1 shows that the motor speed is very dominant in a pump's ability to maintain cell viability during recirculation.

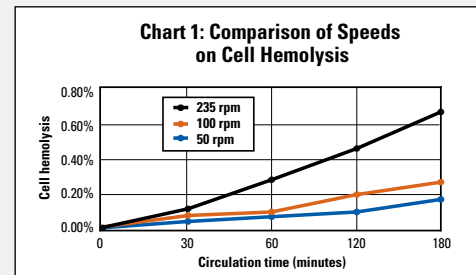

Pump Head Occlusion

Less tubing occlusion allowed space for the blood cells to shift around the force of the roller which decreased the overall percent of hemolysis. Chart 2 compares the effect of flat rollers versus convex rollers on pumps running at the same speed. In this case, equipping a pump head with less than full occlusion improves cell viability 10 to 25%.

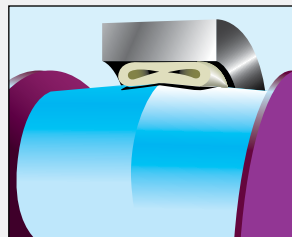

Convex roller

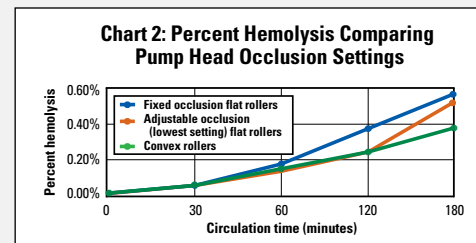

L/S® PTFE-TUBING PUMP HEAD

FEATURES/BENEFITS

- ▶ Flow range: 0.06 to 65 mL/min
- ▶ Transfer aggressive organic solvents and maintain fluid purity
- ▶ Transfer liquid containing small particulates
- ▶ Excellent chemical compatibility
- ▶ Deliver a wide range of flow rates at pressures up to 100 psi
- ▶ Adjustable occlusion
- ▶ Use precision-molded tubing sets

SELECTION CRITERIA

- ▶ Flow rate desired.
 - ▶ Tube size required.
 - ▶ Compatibility with drives.
- See specifications for more information.

Order tubing and drives separately.

COMPATIBILITY WITH DRIVES

- ▶ Mount on all Masterflex L/S drives that accept two or more pump heads

PUMP HOUSING SPECIFICATIONS

- ▶ Pump body, bearing support, and rotor plates are anodized aluminum
- ▶ Rotor shaft, bearing, rollers, and hardware are stainless steel
- ▶ Occlusion bed: acetal
- ▶ ABS plastic occlusion knob

NOTES

Use only Masterflex PTFE-tubing sets with the Masterflex PTFE-tubing pump head to ensure optimal performance. Use of other tubing may void applicable warranties.

ROLLER/ROTOR SPECIFICATIONS

300-Series Stainless Steel (SS)

- ▶ Humidity from 0% to 100%
- ▶ Operating temperature from 0 to 40°C (32 to 104°F)
- ▶ Fluid temperature from 0 to 100°C (32 to 212°F)
- ▶ Ball-bearing construction
- ▶ Continuous duty up to 300 rpm



PTFE-tubing pump head 77390-00



PTFE tubing pump head 77390-00 shown on L/S variable-speed console drive 07528-20 is ideal for transferring aggressive organic solvents.

ISO9001:2008
CERTIFIED SUPPLIER

2 year
warranty

ORDERING INFORMATION

Catalog number	Description
HL-77390-00	L/S PTFE-tubing pump head only

PTFE-TUBING SETS AND ACCESSORIES

PTFE-Tubing Sets include two 38 cm (15") lengths and cannot be substituted with ordinary PTFE tubing. Choose compression fittings below to adapt tubing sets to your system.

[HL-77390-50](#) PTFE-tubing set, 4-mm OD, 2-mm ID. Set of two 38-m (15") lengths.

[HL-77390-60](#) PTFE-tubing set, 6-mm OD, 4-mm ID. Set of two 38-m (15") lengths.

For 4-mm OD PTFE-Tubing Sets

[HL-31321-61](#) Straight connector, 2.8 bar (40 psi) max pressure

[HL-31321-62](#) Male pipe adapter with 1/8" NPT(M) connection

[HL-31321-63](#) Male pipe adapter with 1/4" NPT(M) connection

[HL-06605-53](#) PTFE extension tubing, 4-mm OD. Pack of 7.6 m (25 ft)

For 6-mm OD PTFE-Tubing Sets

[HL-31321-64](#) Straight connector, 9.2 bar (135 psi) max pressure

[HL-31321-43](#) Male pipe adapter with 1/4" NPT(M) connection

[HL-06605-54](#) PTFE extension tubing, 6-mm OD. Pack of 7.6 m (25 ft)

[HL-31321-49](#) Tubing grooving tool. Use when connections must withstand 40 psi (2.8 bar) or greater



PTFE tubing sets,
PTFE extension tubing,
and straight connectors.

Distributed by:
Fiedler Scientific Instruments, s.r.o.
info@lab-eu.com info@pristroje.cz

SPECIFICATIONS for L/S PTFE-Tubing Pump Head

Catalog number		HL-77390-00
Performance Specifications		
Flow capacity	4-mm OD tubing	0.06 to 17 mL/min (0 to 0.27 GPH)
	6-mm OD tubing	0.25 to 65 mL/min (0 to 1.1 GPH)
Max rpm		300
Number of rollers		6
Vacuum lift		2.4 m H ₂ O (8 ft H ₂ O)
Maximum Torque [pumping water at 0 psi, 21°C (70°)]		
PTFE tubing		12.9 kg-cm (180 oz-in)
Physical Specifications		
Pump body, bearing support, and rotor plates material		Anodized aluminum
Rotor shaft, bearings, rollers, and hardware material		Stainless steel
Reversible		Yes
Run dry		No†
Operating temperature		0 to 40°C (32 to 104°F)
Shipping weight		1.5 kg (3.3 lb)

†Do not pump gases or run dry for long periods of time; run dry to prime only.

COMPLETE L/S PTFE-TUBING PUMP SYSTEM

Applications

- ▶ Pumping high-purity fluids
- ▶ Transfer of aggressive chemicals
- ▶ Chemical feed and metering
- ▶ Filtration

Benefits

- ▶ Flow rate: 0.75 to 65 mL/min; pressure up to 100 psi (6.9 bar)
- ▶ Low-pulsation, six-roller pump head
- ▶ Continuous-duty drive displays speed (rpm) and direction

Complete system includes: L/S PTFE tubing pump head 77390-00, 6-mm OD PTFE tube set 77390-60, L/S 300 rpm variable-speed console drive 07528-20, and two ¼" NPT(M) pipe adapters.



Drive is



Catalog number	Power
HL-77912-10	90 to 260 VAC, 50/60 Hz

Dimensional Drawings cm (in.) 77390-00

FRONT

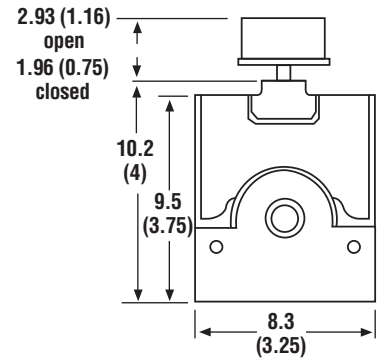

SIDE

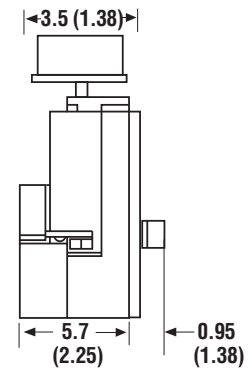

Decay of Initial Flow vs. Time at 300 rpm

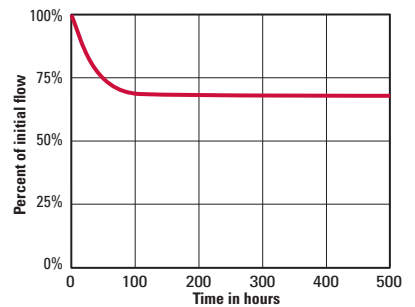

HOW TO LOAD YOUR PUMP HEAD



1. Rotate locking ring then rotate the knob on top of the pump counterclockwise. Lift occlusion bed by sliding it out the front of the body assembly.



2. Install the PTFE tubing assembly in the occlusion bed groove.



3. Slide the occlusion assembly back onto the body assembly and tighten knob.

L/S® TUBING
L/S® DRIVES
L/S® PUMP SYSTEMS.....

ACCESSORIES.....

TECHNICAL DATA.....

L/S® MULTICHANNEL PUMP HEADS FOR MICROBORE PUMP TUBING

FEATURES/BENEFITS

- Four- or eight-channel heads are stackable for up to 32 synchronous flow channels
- Deliver flow rates from 0.00005 to 200 mL/min per channel (flow rates depend on drive rpm and tubing size)
- Six rollers deliver low-pulsation flow
- Excellent between-channel accuracy
- Anodized aluminum and stainless steel construction for durability and reliable, continuous-duty operation up to 600 rpm
- Two-stop tubing sets are easy to load with no occlusion or retention adjustment—order tubing sets separately below
- Accept microbore two-stop tube sets from 0.19 to 2.79 mm ID for a wide flow range

Note: Multichannel pump heads require two-stop tube sets and cannot be loaded with continuous tubing.

SELECTION CRITERIA

- Flow rate and tubing size desired.
- Number of channels needed.
- Compatibility with drives.

Mounting hardware and hex key tool included.
See specifications for more information.

Order tubing and drives separately.

COMPATIBILITY WITH DRIVES

- Mount on all Masterflex L/S drives that accept two or more pump heads; 1/10 hp minimum

PUMP HOUSING SPECIFICATIONS

- Black anodized aluminum frame and gray, hardcoat anodized aluminum occlusion beds

ROLLER/ROTOR SPECIFICATIONS

- Rollers, bearings, rotor plates, and rotor shaft are made of 303 stainless steel
- Good protection from corrosive liquids/vapors
- Humidity: 10 to 90% noncondensing
- Shielded stainless steel ball bearings
- Continuous duty up to 600 rpm



Multichannel pump head 07534-04 for microbore tubing

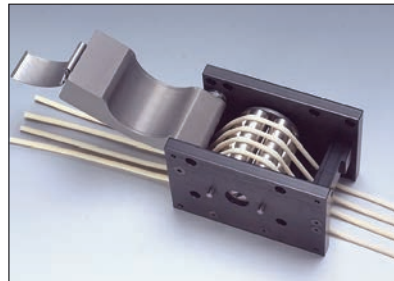

Six rollers deliver accurate, low-pulsation flow.



Stack heads for up to 32 channels.

MULTICHANNEL CAPABILITIES

- Stack heads up to the limits detailed under "Specifications" on facing page
- Mounting hardware and hex key tool are included with each pump head; hardware set attaches head to drive and/or head to head

ISO 9001:2008
CERTIFIED SUPPLIER

2 year
warranty

ORDERING INFORMATION

Catalog number	Number of channels
Multichannel pump heads for microbore pump tubing, 0.19 to 2.79 mm ID	
HL-07534-04	4
HL-07534-08	8

ACCESSORIES

HL-07534-01 Replacement mounting hardware set, includes four mounting screws and hex key tool.

MICROBORE TWO-STOP PUMP TUBING SET FLOW RATES & ORDERING INFORMATION

Flow Rate Information (mL/min per channel using microbore two-stop tubing sets below)

Drive rpm	Microbore pump tubing					
	0.19 mm ID	0.25 mm ID	0.89 mm ID	1.42 mm ID	2.06 mm ID	2.79 mm ID
1 to 100	0.0026 to 0.26	0.0053 to 0.53	0.054 to 5.4	0.12 to 12	0.23 to 23	0.35 to 35
6 to 600	Not recommended†	Not recommended†	0.30 to 30	0.67 to 67	1.3 to 130	2.0 to 200

†Maximum recommended speed for these tubing sizes is 300 rpm.

Microbore Two-Stop Tubing Set Ordering Information

Tubing ID (mm)	Platinum-cured silicone	Santoprene®	Tygon® E-LFL	Viton®
0.19	—	—	HL-06447-10	—
0.25	—	HL-06431-12	HL-06447-12	—
0.89	HL-06421-26	HL-06431-26	HL-06447-26	HL-96428-26
1.42	HL-06421-34	HL-06431-34	HL-06447-34	HL-96428-34
2.06	HL-06421-42	HL-06431-42	HL-06447-42	HL-96428-42
2.79	HL-06421-48	HL-06431-48	HL-06447-48	HL-96428-48
Qty/pk	6	12	12	12

Order microbore extension tubing on pages 34 and 36.

Distributed by:
 Fiedler Scientific Instruments, s.r.o.
 info@lab-eu.com info@pristroje.cz

SPECIFICATIONS for L/S Multichannel Pump Heads

Catalog number	HL-07534-04		HL-07534-08	
Performance Specifications				
Flow capacity per channel	0.00005 to 200 mL/min (0 to 3.2 GPH)			
Number of channels	4		8	
Max number of channels with stacked heads [†]	100-rpm drive	32		
	600-rpm drive	28		
Max rpm	600			
Number of rollers	6			
Torque Specifications [a single pump head pumping water at 0 psi, 21°C (70°F)][‡]				
Santoprene®	Starting torque	7.2 kg-cm (100 oz-in)	9.0 kg-cm (125 oz-in)	
	Running torque	2.2 kg-cm (30 oz-in)	2.9 kg-cm (40 oz-in)	
PVC	Starting torque	10.8 kg-cm (150 oz-in)	13.7 kg-cm (190 oz-in)	
	Running torque	6.1 kg-cm (85 oz-in)	7.9 kg-cm (110 oz-in)	
Silicone	Starting torque	4.3 kg-cm (60 oz-in)	5.0 kg-cm (70 oz-in)	
	Running torque	1.8 kg-cm (25 oz-in)	2.2 kg-cm (30 oz-in)	
Physical Specifications				
Housing material	Anodized aluminum			
Rotor material	Stainless steel			
Operating temperature	0 to 40°C (32 to 104°F)			
Shipping weight	1.8 kg (4 lb)	2.3 kg (5 lb)		

[†]With softer formulations such as silicone; max number of channels will be less with firmer tubing.
[‡]All channels loaded with specified tubing formulations.

COMPLETE L/S MULTICHANNEL PUMP SYSTEM

Applications

- ▶ Multichannel, low-volume dispensing
- ▶ Meter fluids through multiple lines

Benefits

- ▶ Flow rate: 0.35 to 35 mL/min per channel
- ▶ Synchronous flow from four separate channels
- ▶ Low-pulsation, six-roller pump head
- ▶ Continuous-duty drive displays speed (rpm) and direction

Complete system includes: L/S multichannel pump head 07534-04, 2.79 mm ID PVC tube set 06416-48, L/S 100-rpm variable-speed console drive 07528-30.



Drive is



See pages 110 and 112 for more complete L/S Multichannel Pump Systems

Catalog number	Power
HL-77925-10	90 to 260 VAC, 50/60 Hz

Dimensional Drawings cm (in.) 07534-series

FRONT

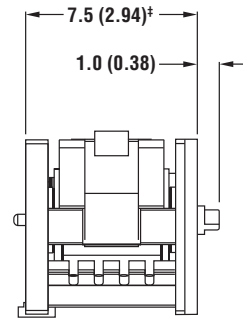

[‡]7.5 [2.94] for single-bed pump heads; 12.2 [4.8] for dual-bed pump heads.

SIDE

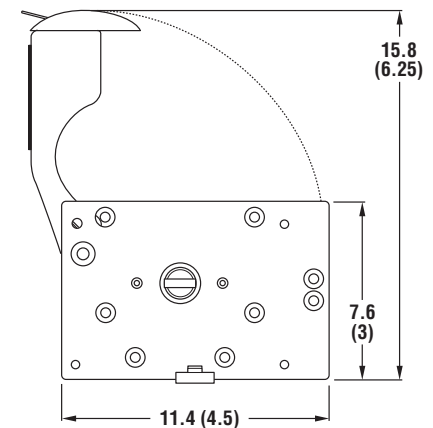

FOR THE LATEST...

Masterflex technical resources, see

- ColeParmer.com
- Masterflex.com

HOW TO LOAD YOUR PUMP HEAD

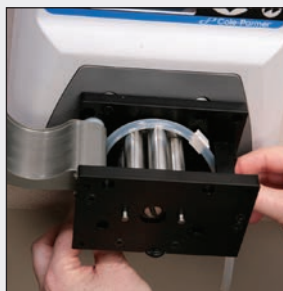

1. Release latch and open occlusion bed; place tubing over rollers and thread ends through retainer slots.



2. Hook left side tubing stop underneath retainer slot.

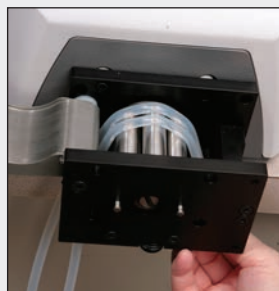

3. Stretch tubing and hook right side stop underneath retainer slot. Close and latch occlusion bed.

L/S® TUBING
 L/S® DRIVES
 L/S® PUMP SYSTEMS.....

ACCESSORIES.....

TECHNICAL DATA.....

L/S® MULTICHANNEL PUMP HEADS FOR L/S® PUMP TUBING

FEATURES/BENEFITS

- Two-, four-, or eight-channel heads are stackable for up to 24 synchronous flow channels
- Deliver flow rates from 0.0009 to 2300 mL/min per channel
- Six-roller heads deliver smooth, low-pulsation flow; three-roller heads offer higher flow rates
- Excellent between-channel accuracy makes these heads ideal for multi-channel dispensing applications
- Anodized aluminum and stainless steel construction for durability and reliable, continuous-duty operation up to 600 rpm
- Two-stop tubing sets are easy to load with no occlusion or retention adjustment—order tubing sets on facing page
- Accept Masterflex® L/S Precision and High-performance precision pump tubing sizes L/S 13, L/S 14, L/S 16, L/S 15, L/S 24, and L/S 35

Note: Multichannel pump heads require two-stop tube sets and cannot be loaded with continuous tubing.

SELECTION CRITERIA

- Flow rate and tubing size desired.
 - Number of channels needed.
 - Compatibility with drives.
- Mounting hardware, hex key tool included.
See specifications for more information.
Order tubing and drives separately.

COMPATIBILITY WITH DRIVES

- Mount on all Masterflex L/S drives that accept two or more pump heads; 1/10 hp minimum

PUMP HOUSING SPECIFICATIONS

- Black anodized aluminum frame and gray, hardcoat anodized aluminum occlusion beds

ROLLER/ROTOR SPECIFICATIONS

- Good protection from corrosive liquids/vapors
- Humidity: 10 to 90% noncondensing
- Shielded stainless steel ball bearings
- Continuous duty up to 600 rpm
- Rollers, bearings, rotor plates, and rotor shaft are made of 303 stainless steel



Multichannel pump head 07535-08 for L/S Precision pump tubing



Multichannel pump head 07536-04 for L/S High-performance precision pump tubing



Stack heads for up to 24 channels.

MULTICHANNEL CAPABILITIES

- Stack heads up to the limits detailed under "Specifications" on facing page
- Mounting hardware and hex key tool are included with each pump head; hardware set attaches head to drive and/or head to head

ISO9001:2008
CERTIFIED SUPPLIER

2 year
warranty

ORDERING INFORMATION







Catalog number	Number of channels
Multichannel pump heads for Precision pump tubing, sizes L/S 13, L/S 14, L/S 16	
HL-07535-04	4
HL-07535-08	8
Multichannel pump heads for High-performance Precision pump tubing, sizes L/S 15, L/S 24, L/S 35	
HL-07536-02	2
HL-07536-04	4

ACCESSORIES

[HL-07534-01](#) Replacement mounting hardware set, includes four mounting screws and hex key tool

L/S PUMP TUBING FLOW RATE INFORMATION

Order Masterflex L/S two-stop Precision pump tubing sets on facing page; order L/S Precision extension tubing on pages 68–73.

Tubing cross sections	L/S Precision pump tubing			L/S high-performance Precision pump tubing		
	 L/S 13	 L/S 14	 L/S 16	 L/S 15	 L/S 24	 L/S 35
Flow rate—mL/rev	0.045	0.16	0.47	1.6	2.8	3.8
mL/min @ 600 rpm	27	96	280	1000	1700	2300
Max pressure†	2.7 bar (40 psi)					2.4 bar (35 psi)
Max vacuum†	660 mm Hg (26" Hg)					
Suction lift	8.8 m H ₂ O (29 ft H ₂ O)					

†Actual performance varies depending upon tubing materials—see pages 20–24 and 172–192 for more information.

SPECIFICATIONS for L/S Multichannel Pump Heads

Catalog number	HL-07535-04	HL-07535-08	HL-07536-02	HL-07536-04	
Performance Specifications					
Flow capacity per channel	0.0009 to 280 mL/min (0 to 4.4 GPH)		0.032 to 2300 mL/min (0 to 36 GPH)		
Number of channels	4	8	2	4	
Max number of channels with stacked heads†	100-rpm drive	24	12		
	600-rpm drive	12	6		
Max rpm	600		600		
Number of rollers	6		3		
Torque Specifications [a single pump head pumping water at 0 psi, 21°C (70°F)]‡					
PharMed® BPT	Starting torque	19.8 kg-cm (275 oz-in)	32.4 kg-cm (450 oz-in)	20.5 kg-cm (285 oz-in)	37 kg-cm (515 oz-in)
	Running torque	3.6 kg-cm (50 oz-in)	5.4 kg-cm (75 oz-in)	4.0 kg-cm (55 oz-in)	6.8 kg-cm (95 oz-in)
Tygon®, Viton®	Starting torque	25.1 kg-cm (350 oz-in)	33.5 kg-cm (465 oz-in)	21.2 kg-cm (295 oz-in)	37.4 kg-cm (520 oz-in)
	Running torque	8.3 kg-cm (115 oz-in)	11.2 kg-cm (155 oz-in)	6.8 kg-cm (95 oz-in)	12.9 kg-cm (180 oz-in)
Silicone	Starting torque	11.9 kg-cm (165 oz-in)	16.9 kg-cm (235 oz-in)	12.9 kg-cm (180 oz-in)	20.9 kg-cm (290 oz-in)
	Running torque	2.5 kg-cm (35 oz-in)	4.0 kg-cm (55 oz-in)	2.9 kg-cm (40 oz-in)	5.4 kg-cm (75 oz-in)
Physical Specifications					
Housing material	Anodized aluminum				
Rotor material	Stainless steel				
Operating temperature	0 to 40°C (32 to 104°F)				
Shipping weight	1.8 kg (4 lb)	2.3 kg (5 lb)	1.8 kg (4 lb)	2.3 kg (5 lb)	

†With softer formulations such as silicone; max number of channels will be less with firmer tubing.

‡All channels loaded with specified tubing formulation.

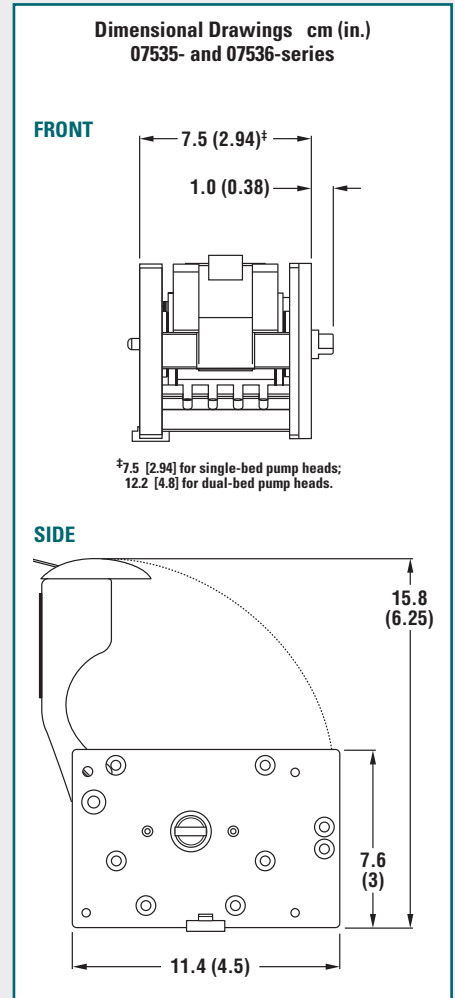

HOW TO LOAD YOUR PUMP HEAD



1. Release latch and open occlusion bed; place tubing over rollers and thread ends underneath retainer slots.



2. Hook left side tubing stop underneath retainer slot.



3. Stretch tubing and hook right side stop underneath retainer slot. Close and latch occlusion bed.

L/S® TUBING
L/S® DRIVES
L/S® PUMP SYSTEMS.....

ACCESSORIES.....

TECHNICAL DATA.....

L/S TWO-STOP PUMP TUBING SETS ORDERING INFORMATION

Pump tubing formulation	L/S Precision pump tubing			L/S High-performance Precision pump tubing		
	L/S 13	L/S 14	L/S 16	L/S 15	L/S 24	L/S 35
Tygon® E-LFL NEW	HL-06447-13	HL-06447-14	HL-06447-16	HL-06447-15	HL-06447-24	HL-06447-35
Silicone (platinum-cured)	HL-06421-13	HL-06421-14	HL-06421-16	HL-06421-15	HL-06421-24	HL-06421-35
BioPharm Plus silicone (platinum-cured)	HL-96116-13	HL-96116-14	HL-96116-16	HL-96116-15	HL-96116-24	HL-96116-35
PharMed® BPT	HL-96114-13	HL-96114-14	HL-96114-16	HL-96114-15	HL-96114-24	HL-96114-35
Chem-Durance® Bio	HL-96117-13	HL-96117-14	HL-96117-16	HL-96117-15	HL-96117-24	HL-96117-35
Viton®	HL-96428-13	HL-96428-14	HL-96428-16	HL-96428-15	HL-96428-24	HL-96428-35
Qty/pk	8	8	8	4	4	4

L/S® MULTICHANNEL CARTRIDGE PUMP HEADS

FEATURES/BENEFITS

- ▶ Synchronous multichannel pumping
- ▶ Deliver flow rates from 0.005 to 1700 mL/min per channel with Masterflex L/S® or microbore tubing (flow rates depend on drive rpm and tubing size)
- ▶ Use 4 large cartridges, 8 small cartridges, or any combination of both
- ▶ Up to eight channels with a single head
- ▶ Use one cartridge or fill the pump head
- ▶ Each cartridge is individually adjustable
- ▶ Precision molded housing and tubing cavity
- ▶ Adapts easily to OEM applications

COMPATIBILITY WITH DRIVES

- ▶ Mount on most drives accepting Masterflex L/S pump heads

For more information, see specific drive pages.

SELECTION CRITERIA

1. Flow rate, tubing size desired.
 2. Number of channels needed.
 3. Drive compatibility.
- See specifications for more information.

Order tubing and drives separately.

PUMP HOUSING SPECIFICATIONS

Molded Polysulfone Body

- ▶ General-purpose applications
- ▶ Adjustable foot provided for head support

ROLLER/ROTOR SPECIFICATIONS

300-Series Stainless Steel (SS) for 07519-06

Anodized Aluminum for 07519-05

- ▶ General-purpose applications
- ▶ Buna N shielded ball-bearing construction
- ▶ Continuous duty up to 600 rpm

See specifications for maximum drive rpm.

CARTRIDGE SPECIFICATIONS

Polycarbonate and Glass-Filled Nylon

- ▶ No tools required/mechanically stable
- ▶ Anodized aluminum occlusion knob

Tangential Occlusion

- ▶ Better flow performance
- ▶ Fine tune flow rates ±5%
- ▶ Flow characteristics virtually the same in each direction of rotation
- ▶ Increase occlusion for priming/greater pressure
- ▶ Decrease occlusion to extend tubing life
- ▶ Index scale on cartridge to reference set occlusion
- ▶ Use microbore and Masterflex L/S Precision tubing sizes

ISO9001:2008
CERTIFIED SUPPLIER

2 year
warranty

ORDERING INFORMATION

Pump Heads

Catalog number	Max number of cartridges accepted†	Gear reduction	Max drive speed
Three-roller pump head			
HL-07519-05	4 large or 8 small	1:1	600
Four-roller pump head			
HL-07519-06	4 large or 8 small	1:1	600

†Pump heads accept both large and small cartridges—one large cartridge occupies the same space as two small ones. Use 4 large cartridges, 8 small cartridges, or any combination of both.

Cartridges

Catalog number	Tubing sizes accepted
Large cartridge	
HL-07519-70	Masterflex L/S 14, 16, 25, 17†
Small cartridge	
HL-07519-80	Microbore two-stop tubing sets, 0.89 mm and larger, or Masterflex tubing sizes L/S 13 and L/S 14

‡Only C-FLEX® and silicone tubing formulations are recommended for L/S 17.



Three-roller pump head
07519-05



Four-roller pump head
07519-06

NOTES

Use only Masterflex pump tubing with Masterflex pumps to ensure optimal performance. Use of other tubing may void applicable warranties.

SPECIFICATIONS & FLOW RATE INFORMATION (mL/MIN PER CHANNEL)

Pump head model	No. of rollers	Maximum no. of cartridges accepted	Gear ratio	Drive rpm	Pump tubing sizes (Order microbore two-stop tubing sets on page 57 and Masterflex pump tubing on pages 68–73.††)					
					0.19 mm ID	0.25 mm ID	0.89 mm ID	1.42 mm ID	2.06 mm ID	2.79 mm ID
Using microbore two-stop tubing sets										
HL-07519-05	3	4 large or 8 small	1:1	6 to 600	Not recommended	0.44 to 44	1.0 to 100	2.2 to 220	3.8 to 380	
				0.1 to 100	Not recommended	0.007 to 7.4	0.017 to 17	0.037 to 37	0.063 to 63	
HL-07519-06	4	4 large or 8 small	1:1	6 to 600	Not recommended	0.44 to 44	1.0 to 100	2.2 to 220	3.8 to 380	
				0.1 to 100	Not recommended	0.007 to 7.4	0.017 to 17	0.037 to 37	0.063 to 63	
Using Masterflex precision pump tubing										
HL-07519-05	3	4 large or 8 small	1:1	6 to 600	L/S 13	L/S 14	L/S 16	L/S 25	L/S 17††	
				0.1 to 100	0.30 to 30	1.3 to 130†††	4.6 to 460	10 to 1000	17 to 1700	
HL-07519-06	4	4 large or 8 small	1:1	6 to 600	0.005 to 5	0.021 to 21	0.076 to 76	0.17 to 170	0.28 to 280	
				0.1 to 100	0.28 to 28	1.2 to 120	3.8 to 380	8.3 to 830	14 to 1400	
					0.005 to 4.7	0.020 to 20	0.063 to 63	0.14 to 140	0.23 to 230	

††Only C-FLEX and silicone formulations are recommended for L/S 17.

†††Tygon® E-Food and Viton (L/S sizes) are not recommended for multichannel cartridge pump heads.

††††Use a maximum of six 07519-70 cartridges when using L/S 14 Norprene®, PharMed® BPT, or Tygon tubing formulations at higher speeds with pump head 07519-05.

Distributed by:
Fiedler Scientific Instruments, s.r.o.
info@lab-eu.com info@pristroje.cz

SPECIFICATIONS for L/S Multichannel Cartridge Pump Heads

Catalog number	HL-07519-05	HL-07519-06
Performance Specifications		
Flow capacity per channel	0.005 to 1700 mL/min (0 to 27 GPH)**	
Max rpm	600	
Number of rollers	3	4
Maximum vacuum/suction lift	660 mm Hg (26" Hg)/8.8 m H ₂ O (29 ft H ₂ O)	
Torque data	Please see pages 172–192	
Physical Specifications		
Housing/Rotor material	Stainless steel/anodized aluminum	Stainless steel
Operating temperature	0 to 40°C (32 to 104°F)	
Shipping weight	1.5 kg (3.3 lb)	

**Depending on drive, pump head, and tubing size selected.

MULTICHANNEL CAPABILITIES

- Mount one pump head with up to eight cartridges on a single drive
- No tools required to insert, remove, or adjust the cartridges
- Change tubing without disturbing other cartridges—eliminates lost time

Mounting hardware
and tool supplied with pump head.

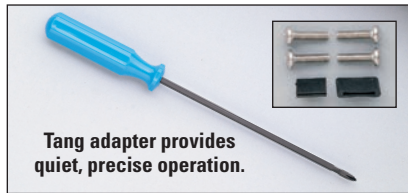

MORE INFO



Tubing size settings on our cartridges allow you to simply select your tubing size for exact tubing retention every time!

Shown: Large cartridge 07519-70 (order separately on page 56).

ORDERING INFORMATION

Microbore Two-Stop Pump Tubing Sets (for 07519-80 small cartridge)

Tubing ID (mm)	Platinum-cured silicone	Santoprene	Tygon® E-LFL	Viton®
0.89	HL-06421-26	HL-06431-26	HL-06447-26	HL-96428-26
1.42	HL-06421-34	HL-06431-34	HL-06447-34	HL-96428-34
2.06	HL-06421-42	HL-06431-42	HL-06447-42	HL-96428-42
2.79	HL-06421-48	HL-06431-48	HL-06447-48	HL-96428-48
Qty/pk	6	12	12	12

HOW TO LOAD YOUR PUMP HEAD



1. Select tubing, load tubing into cartridge, and set tubing retainers.



2. Snap cartridge into place on pump head.



3. Adjust occlusion using index scale on cartridge.

Dimensional Drawings cm (in.) 07519-05, -06 Pump Heads

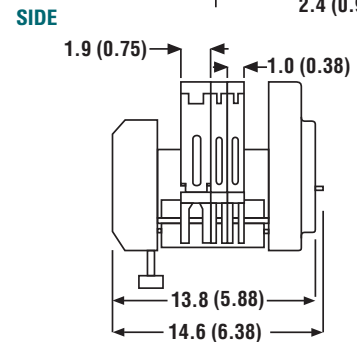
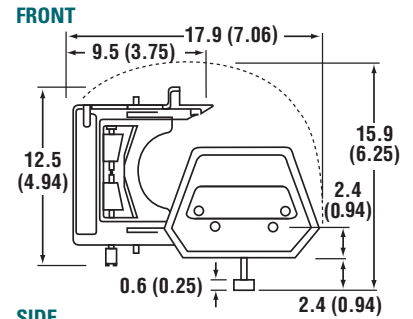

07519-70, -80 Cartridges

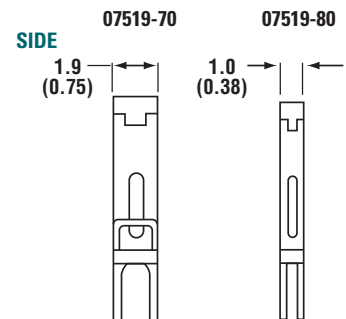
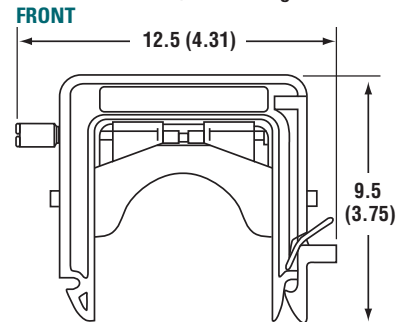

L/S® TUBING
L/S® DRIVES
L/S® PUMP SYSTEMS.....

ACCESSORIES.....

TECHNICAL DATA.....

L/S® REDUCED-PULSATION CARTRIDGE PUMP HEADS

FEATURES/BENEFITS

- ▶ Synchronous multichannel pumping
- ▶ Deliver flow rates from 0.00005 to 350 mL/min per channel (flow rates depend on drive rpm and tubing size)
- ▶ Use up to 6 large cartridges or up to 12 small cartridges
- ▶ Use just one cartridge or fill the pump head
- ▶ Adapts easily to OEM applications

SELECTION CRITERIA

1. Pump head compatibility.
 2. Flow rate and tubing size.
- See specifications for more information.

Order tubing and drives separately.

COMPATIBILITY WITH DRIVES

- ▶ Mount on most Masterflex L/S drives
- See specific drive pages for more information.

PUMP HOUSING SPECIFICATIONS

Molded Polysulfone Housing
300-Series Stainless Steel (SS) Rotors and Bearings

Rulon® Rollers

- ▶ Adjustable foot on long heads for support
- See specifications for maximum drive rpm.

CARTRIDGE SPECIFICATIONS

Polycarbonate and Glass-Filled Nylon

- ▶ No tools required/mechanically stable
- ▶ Anodized aluminum occlusion knob

Offset Tangential Occlusion

- ▶ Better flow performance
- ▶ Fine tune flow rate ±5%
- ▶ Flow characteristics virtually the same in each direction of rotation (see note on facing page regarding reduced-pulsation setup)
- ▶ Increase occlusion for priming/greater pressure
- ▶ Decrease occlusion to extend tubing life
- ▶ Index scale on cartridge
- ▶ Use microbore and Masterflex L/S Precision pump tubing sizes

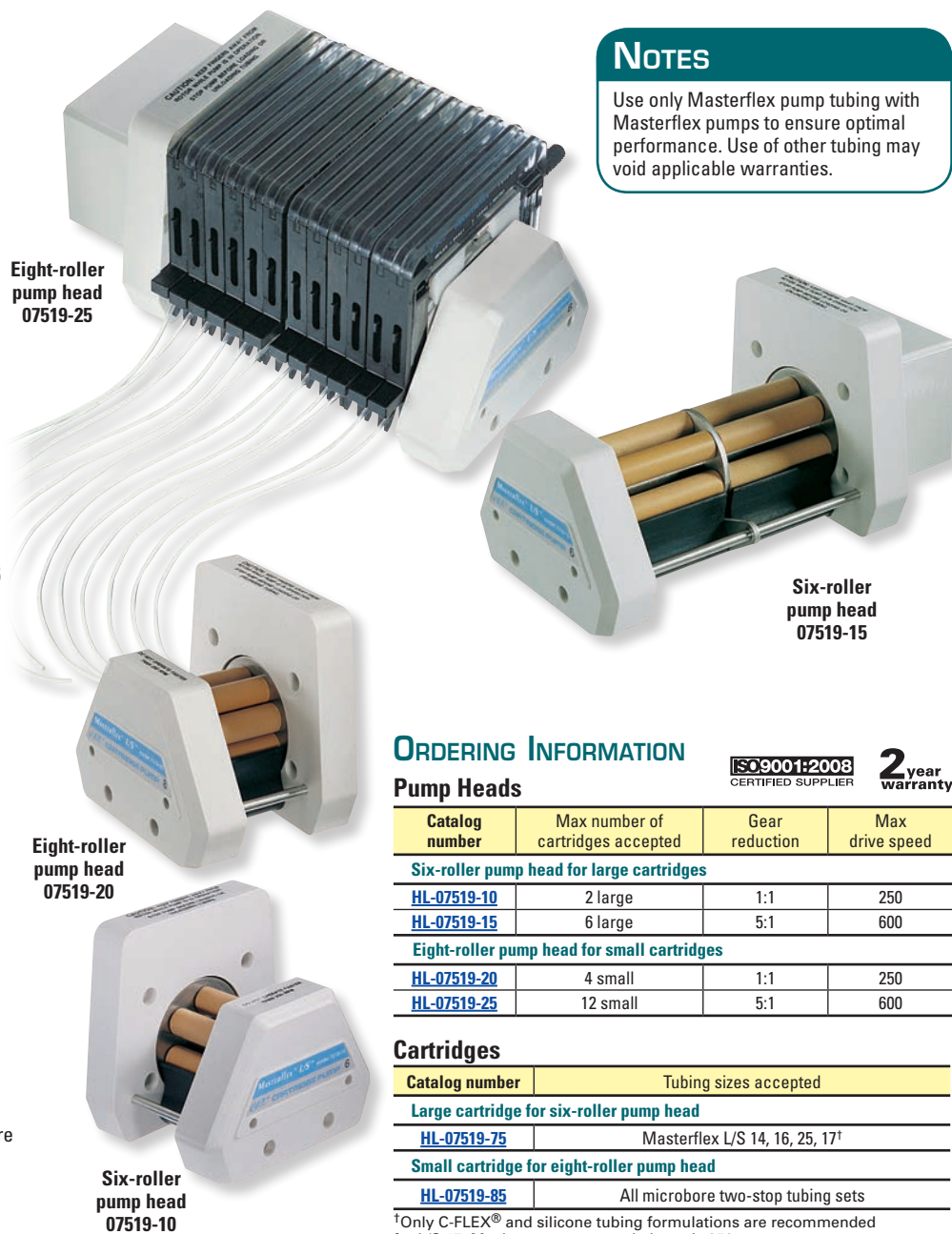

NOTES
Use only Masterflex pump tubing with Masterflex pumps to ensure optimal performance. Use of other tubing may void applicable warranties.

ORDERING INFORMATION

ISO9001:2008 CERTIFIED SUPPLIER **2** year warranty

Pump Heads

Catalog number	Max number of cartridges accepted	Gear reduction	Max drive speed
Six-roller pump head for large cartridges			
HL-07519-10	2 large	1:1	250
HL-07519-15	6 large	5:1	600
Eight-roller pump head for small cartridges			
HL-07519-20	4 small	1:1	250
HL-07519-25	12 small	5:1	600

Cartridges

Catalog number	Tubing sizes accepted
Large cartridge for six-roller pump head	
HL-07519-75	Masterflex L/S 14, 16, 25, 17†
Small cartridge for eight-roller pump head	
HL-07519-85	All microbore two-stop tubing sets

†Only C-FLEX® and silicone tubing formulations are recommended for L/S 17. Maximum recommended rpm is 250.

SPECIFICATIONS & FLOW RATE INFORMATION (mL/MIN PER CHANNEL)

Pump head model	No. of rollers	Maximum no. of cartridges accepted‡	Gear ratio	Drive rpm	Pump tubing sizes (Order microbore two-stop tubing sets on page 57 and Masterflex pump tubing on pages 68–73††.)					
					0.19 mm ID	0.25 mm ID	0.89 mm ID	1.42 mm ID	2.06 mm ID	2.79 mm ID
Using microbore two-stop tubing sets										
HL-07519-20	8	4 small	1:1	6 to 250	0.017 to 0.70	0.31 to 1.3	0.31 to 13	0.70 to 29	1.3 to 54	2.0 to 85
				0.1 to 100	0.003 to 0.28	0.0005 to 0.52	0.005 to 5.2	0.012 to 12	0.022 to 22	0.034 to 34
HL-07519-25	8	12 small	5:1	6 to 600	0.0030 to 0.30	0.060 to 0.60	0.062 to 6.2	0.14 to 14	0.26 to 26	0.41 to 41
				0.1 to 100	0.00005 to 0.050	0.0001 to 0.10	0.001 to 1.0	0.002 to 2.3	0.004 to 4.3	0.007 to 6.8
Using Masterflex Precision pump tubing										
HL-07519-10	6	2 large	1:1	6 to 250	—	0.94 to 39	3.1 to 130	5.8 to 240	8.4 to 350	—
				0.1 to 100	—	0.016 to 16	0.052 to 52	0.096 to 96	0.14 to 140	—
HL-07519-15	6	6 large	5:1	6 to 600	—	0.20 to 20	0.65 to 65	1.2 to 120	1.7 to 170	—
				0.1 to 100	—	0.003 to 3.3	0.011 to 11	0.020 to 20	0.028 to 28	—

‡Check pump head torque requirement with drive torque to determine actual number of cartridges.

††Tygon® Food and Viton® (L/S sizes) are not recommended for these reduced-pulsation cartridge pump heads.

‡‡Only C-FLEX® or silicone tubing is recommended for size L/S 17.

Distributed by:
Fiedler Scientific Instruments, s.r.o.
info@lab-eu.com info@pristroje.cz

SPECIFICATIONS for L/S Reduced-Pulsation Cartridge Pump Heads

Catalog number	HL-07519-10	HL-07519-15	HL-07519-20	HL-07519-25
Performance Specifications				
Flow capacity per channel	0.00005 to 350 mL/min (0 to 5.5 GPH) [†]			
Max drive rpm	250 [†]	600 [†]	250 [†]	600 [†]
Number of rollers	6		8	
Torque data	Please see page 172–192			
Physical Specifications				
Housing material	Polysulfone ends			
Rotor/roller material	Stainless steel/Rulon®			
Operating temperature	0 to 40°C (32 to 104°F)			
Shipping weight	2.1 kg (4.5 lb)			

[†]Depending on drive, pump head, and tubing size selected.

REDUCED-PULSATION SETUP

Mount cartridges in opposite directions to use offset occlusion for reduced pulsation.

Connect two discharge tubes together with a Y-connector. This will balance the offset occlusion of each cartridge. The reduced pulsation is measured at the outlet (shown below).

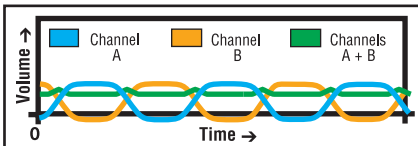

MULTICHANNEL CAPABILITIES

- Mount one pump head with up to 12 cartridges on a single drive with synchronized or offset occlusion for reduced pulsation
- No tools required to insert, remove, or adjust the cartridges
- Change tubing without disturbing other cartridges—eliminates lost time on other channels
- Best performance with 100 rpm, 1/10 hp motors. Can be used with other drives with a reduced number of cartridges



Mounting hardware and tool supplied with pump head

HOW TO LOAD YOUR PUMP HEAD



1. Select tubing, load cartridge, and set tubing retainers.



2. Easily snap cartridge into place on pump head.



3. Adjust occlusion using index scale on cartridge.

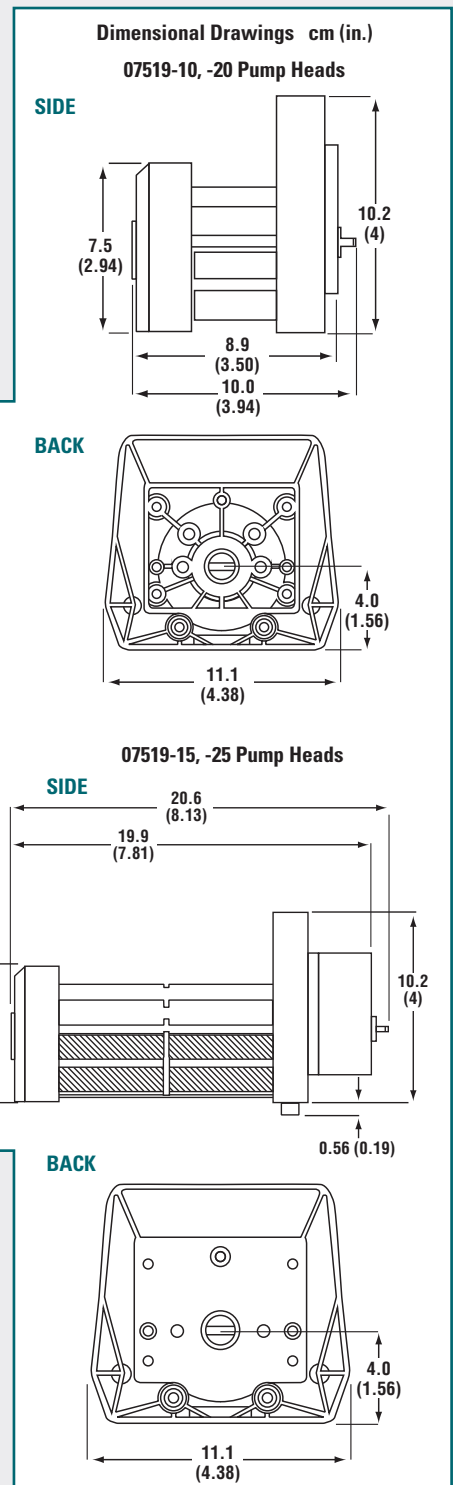

L/S® TUBING
L/S® DRIVES
L/S® PUMP SYSTEMS.....

ACCESSORIES.....

TECHNICAL DATA.....

IDEAL FOR LOW-FLOW OEM PUMPING APPLICATIONS



Customizable—Contact Us for More Options

- Mounting adapters
- Open head sensor
- Colors
- Motors
- Leak detection
- And more...

- No wasted time—takes less than 15 seconds to change tubing
- Fits where you need it—requires just 3¹³/₃₂" x 2¹/₂" for installation, operation, and tube replacement
- Eliminate leakage with continuous tubing—available in several formulations
- Improved repeatability, accuracy, and tubing life with auto tubing retention
- Pump more—available in single- or dual-channel models
- No more maintenance—low-friction roller and sealed ball bearings

MINIFLEX™ PUMP HEADS

Catalog number	Number of channels	Maximum flow rate	Accepts Masterflex® tubing size (inside diameter)
MK-77220-00	1	330 mL/min	L/S® 13 (0.8 mm), L/S 14 (1.6 mm), L/S 16 (3.2 mm), L/S 25 (4.8 mm)
MK-77220-10	2	177 mL/min	L/S 13 (0.8 mm), L/S 14 (1.6 mm), L/S 16 (3.2 mm)

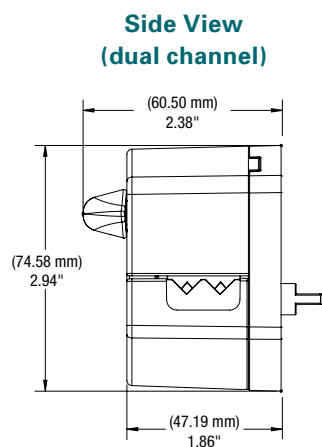
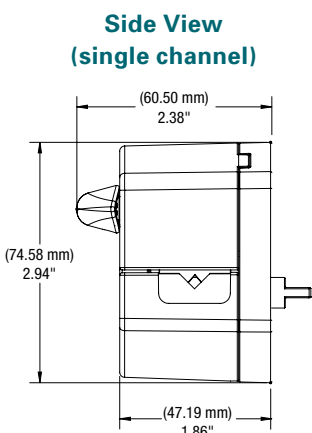
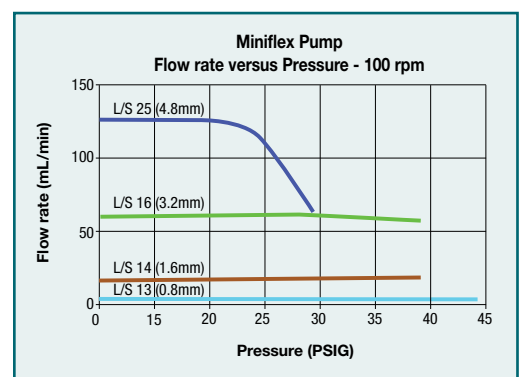
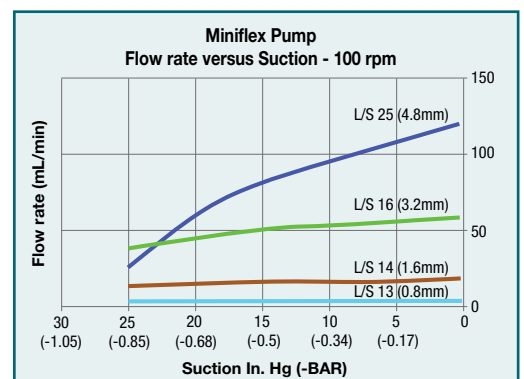
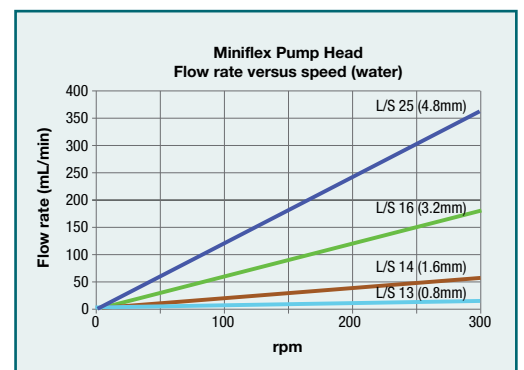

Front View (pump head closed)

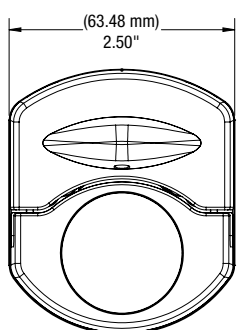

Front View (pump head open)

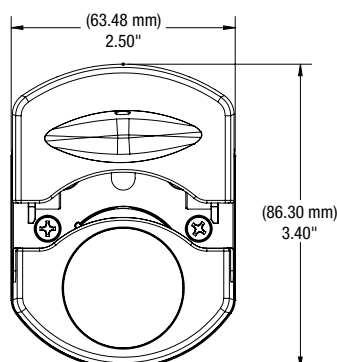

L/S® PTFE-DIAPHRAGM PUMP HEADS

FEATURES/BENEFITS

- ▶ Designed for demanding chemical feed/metering applications
- ▶ Deliver flow rates from 10 to 800 mL/min
- ▶ Run dry without damage
- ▶ Maintain ±2% repeatability across varying system pressures and fluid viscosities
- ▶ Self-priming under wet and dry conditions
- ▶ Compact design minimizes fluid churning and dead volume
- ▶ Handles wide variety of fluids at temperatures up to 66°C (150°F)
- ▶ Pump through filter or into pressurized chamber
- ▶ Easy to clean, inspect, and service
- ▶ Adapts easily to OEM applications

SELECTION CRITERIA

1. Flow rate/pressure required.
2. Materials of construction.
3. Compatibility with drives.

Tang adapters and mounting hardware are supplied with each head.

See specifications for more information.

Order fittings and drives separately.

COMPATIBILITY WITH DRIVES

- ▶ Mount on most Masterflex L/S drives that accept two or more pump heads
- ▶ Drive requirements: minimum 1/10 hp

PTFE-diaphragm pump heads include check valves.



PTFE-diaphragm pump head 07090-42

PUMP HEAD MATERIALS

- ▶ PTFE diaphragm and pump body
- ▶ PTFE valve seat and springs
- ▶ PTFE or borosilicate glass ball checks
- ▶ Cast aluminum housing
- ▶ Tang adapters provide positive connection of pump head to drive for better torque control and quieter operation
- ▶ To determine chemical compatibility of your fluids, see pages 198–206

ISO9001:2008
CERTIFIED SUPPLIER

2 year
warranty

ORDERING INFORMATION

Catalog number	Flow capacity
HL-07090-42	80 to 800 mL/min (1.3 to 13 GPH)
HL-07090-62	10 to 100 mL/min (0.16 to 1.6 GPH)

COMPLETE L/S® PTFE-DIAPHRAGM PUMP SYSTEM

Applications

- ▶ Chemical feed and metering ▶ Chemical injection ▶ High-purity fluid transfer
- ▶ Pumping aggressive chemicals ▶ High-pressure pumping

Benefits

- ▶ Continuous pressure up to 50 psi
- ▶ Excellent chemical compatibility ▶ High metering accuracy
- ▶ Self-priming ▶ PTFE fluid path maintains fluid purity

Features

- ▶ 1/10-hp, 6 to 600 rpm continuous-duty drive ▶ ±0.25% speed control accuracy
- ▶ ABS plastic housing ▶ DB9 female connection on back for remote control



77915-10

SPECIFICATIONS & ORDERING INFORMATION

Catalog number	Flow range (mL/min)	Pump head included	Tubing included†	Tubing sizes accepted	Drive included	Drive speed range (rpm)	Drive IP rating	Power (50/60 Hz)
HL-77915-10	80 to 800	L/S PTFE diaphragm 07090-42	1/4" ID x 3/8" OD PTFE tubing 06605-15; 3.6 m (12 ft)	—	07528-10	40 to 400‡	IP33	90 to 260 VAC

†Also includes pipe adapters and check valve. ‡Recommended drive speed operating range for included pump head.



Distributed by:
 Fiedler Scientific Instruments, s.r.o.
 info@lab-eu.com info@pristroje.cz

SPECIFICATIONS for L/S PTFE-Diaphragm Pump Heads

Catalog number	HL-07090-42	HL-07090-62
Performance Specifications		
Flow capacity	80 to 800 mL/min (1.3 to 13 GPH)	10 to 100 mL/min (0.16 to 1.6 GPH)
Max rpm	400	400
Max pressure	3.4 bar (50 psi) [†]	5.0 bar (75 psi) [†]
Max suction lift (of H ₂ O)	61 cm (24") dry, 4.9 m (16 ft) wet	25.4 cm (10") dry, 3 m (10 ft) wet
Max dead volume	16 mL	2 mL
Intake/discharge ports	¼" NPT(M)	½" NPT(M)
Max fluid temperature	65°C (149°F)	
Liquid viscosity range	1 to 500 cp (6 to 2900 SSU)	
Reversible	Yes (does not affect flow direction)	
Self-priming, wet or dry	Yes	
Cracking pressure	68 m bar (<1 psi)	
Run dry	Yes	
Torque Specifications [pumping water at 0 psi, 21°C (70°F)]		
Starting torque	5.8 kg-cm (80 oz-in)	3.6 kg-cm (50 oz-in)
Running torque	1.6 kg-cm (22 oz-in)	1.3 kg-cm (18 oz-in)
Physical Specifications		
Housing, diaphragm, spring, and valve seat material	PTFE	
Ball check material	PTFE	Borosilicate glass
Operating temperature	0 to 40°C (32 to 104°F)	
Shipping weight	1.5 kg (4 lb)	1.4 kg (3 lb)

[†]Use a pressure relief valve to prevent higher pressures.

ACCESSORIES

For high-flow pump head (07090-42)

[HL-31320-54](#) Female pipe adapter with ¼" NPT(F). Use with ¾" OD tubing.

[HL-06605-35](#) PTFE tubing, ¾" OD x ¼" ID. Pack of 7.6 m (25 ft).

[HL-07090-45](#) External check valve with PTFE ball. Inlet and discharge ports are ¼" NPT(M).

[HL-07090-43](#) Service kit. Contains one PTFE diaphragm, two PTFE check valve assemblies, two drive-tang boots, installation wrench.

For low-flow pump head (07090-62)

[HL-31320-52](#) Female pipe adapter with ½" NPT(F). Use with ¼" OD tubing.

[HL-06605-31](#) PTFE tubing, ¼" OD x 5/32" ID. Pack of 7.6 m (25 ft).

[HL-07090-65](#) External check valve with borosilicate glass ball. Inlet and discharge ports are ½" NPT(M).

[HL-07090-63](#) Service kit. Contains one PTFE diaphragm, two PTFE check valve assemblies, two drive-tang boots, installation wrench.

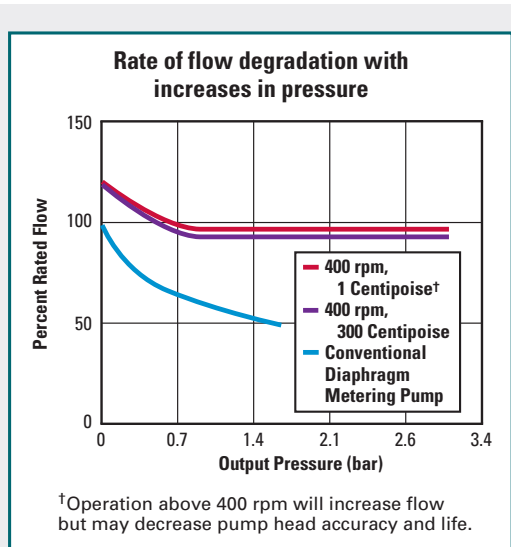

Service kit 07090-63 for PTFE-diaphragm pump head 07090-62

Dimensional Drawings cm (in.) PTFE-Diaphragm Pump Head

SIDE

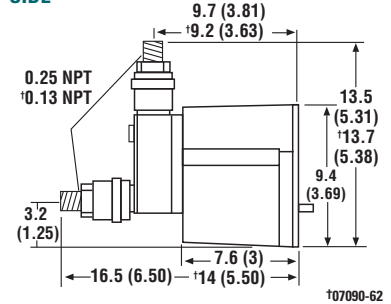

BACK

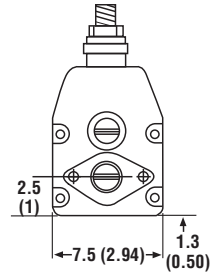

Pump Head Operation:

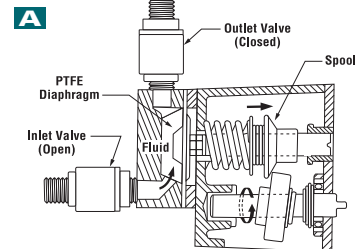

Drive coupling converts rotary to reciprocating motion. On the intake stroke, the PTFE diaphragm is fully retracted, creating a vacuum to open the inlet valve and draw in fluid.

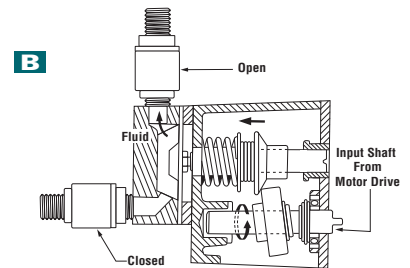

On the discharge stroke, the PTFE diaphragm is driven forward, forcing fluid out through the outlet valve.

L/S® TUBING
 L/S® DRIVES
 L/S® PUMP SYSTEMS.....

ACCESSORIES.....

TECHNICAL DATA.....

MICROPUMP® A-MOUNT GEAR PUMP HEADS

FEATURES/BENEFITS

- ▶ Leak-free delivery of fluids
- ▶ Magnetic drive and single seal keep potential contaminants out
- ▶ Precision-gear pump heads provide smooth, accurate, pulseless fluid delivery
- ▶ Wide range of wetted parts handles a variety of challenging chemicals
- ▶ Compact and easy to service with available service kits and simple hand tools
- ▶ Cavity-style pump heads provide high inlet pressures
- ▶ Suction shoe heads provide higher delivery pressures and superior priming performance
- ▶ Continuous-duty cycle



A
Cavity style design has ability to do reversible flows on models without an internal bypass.



B
Suction shoe design provides constant flow even when pressure changes

SELECTION CRITERIA

1. Flow rate and tubing size desired.
2. Compatibility with drives.
3. Mounting adapter plate for Masterflex® L/S® drives.

See specifications for more information.

Order pump heads and drives separately.

COMPATIBILITY WITH DRIVES

- ▶ Mount on all Masterflex L/S drives using the Micropump pump head adapter for 600-rpm Masterflex L/S drives or mount to one of the Micropump-compatible drives on pages 63–64

HL-07002-15 Micropump pump head adapter kit for 600-rpm Masterflex L/S drives

PUMP HOUSING SPECIFICATIONS

- ▶ 316 stainless steel base material
- ▶ Gears can be constructed of carbon graphite, PTFE, PPS, or PEEK
- ▶ Static seal materials include Viton®, PTFE, Kalrez, and EPDM (some are standard while others may be requested when ordering, see specifications table for standard materials)

SEE PAGES 63 AND 64

To select compatible drives.

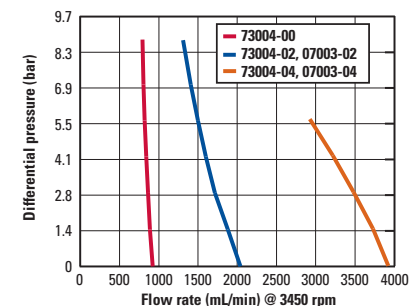
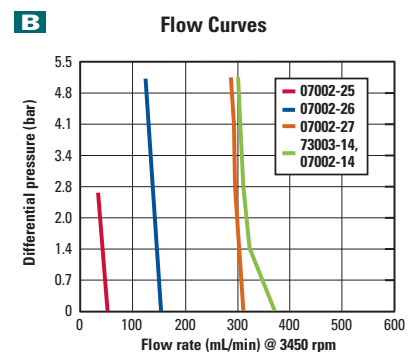
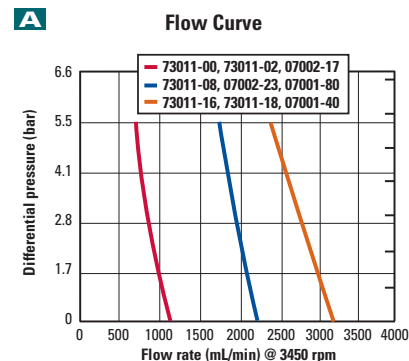

SPECIFICATIONS & ORDERING INFORMATION

Max viscosity: 0.2 to 1500 cp Suction lift: 59.8 millibar (24" of H₂O at 1750 rpm)

Catalog number	Flow rates (mL/min)			Max pressure (bar)		Port size NPT(F)	Wetted parts			Temperature range	Internal bypass	Max speed (rpm)	Service kits Cat. no.			
	mL/rev	at 50 rpm	at 5000 rpm	Diff	System		Body	Gears	Seals							
A Cavity-style pump heads																
HL-73011-00	0.32	16	1600	5.51	20.68	1/8"	316 SS	PEEK	PTFE	-43 to 54°C	No	10,000	HL-73011-80			
HL-73011-02				5.51				PEEK						-43 to 54°C	Yes	HL-73011-80
HL-07002-17				3.44				PTFE						-45 to 76°C	Yes	
HL-07002-23	0.64	32	3200	3.44	20.68	1/8"	316 SS	PTFE	PTFE	-45 to 54°C	Yes	10,000	HL-07002-08			
HL-07001-80				5.17				PPS						HL-07001-89		
HL-73011-08				5.51				PEEK							HL-73011-84	
HL-73011-10	0.64	32	3200	5.51	20.68	1/8"	316 SS	PTFE	PTFE	-43 to 54°C	No	10,000	HL-73011-84			
HL-73011-16				5.51				PEEK						HL-73011-88		
HL-73011-18				5.51				PEEK							HL-73011-88	
HL-07001-40	0.91	45.5	4550	3.44	20.68	1/8"	316 SS	PTFE	PTFE	-43 to 54°C	Yes	10,000	HL-73011-88			
HL-73011-18				5.51				PEEK						HL-73011-88		
HL-07001-40				3.44				PTFE						HL-07001-41		
B Suction shoe pump heads																
HL-07002-25	0.017	0.85	85	1.37	20.68	1/8"	316 SS	Graphite	PTFE	-45 to 176°C	No	8000	HL-07144-42			
HL-07002-26	0.042	2.10	210	2.75	20.68	1/8"	316 SS	Graphite	PTFE	-45 to 176°C	No	8000	HL-07144-44			
HL-07002-27	0.084	4.20	420	2.75	20.68	1/8"	316 SS	Graphite	PTFE	-45 to 176°C	No	8000	HL-07144-47			
HL-73003-14	0.092	4.60	460	5.17	20.68	1/8"	316 SS	PEEK	PTFE	-45 to 176°C	No	8000	HL-73003-94			
HL-07002-14	0.261	13.05	1305	8.61	20.68	1/8"	316 SS	PPS	Viton	-45 to 176°C	Yes	10,000	HL-73004-80			
HL-73004-04								PEEK						HL-73004-88		
HL-73004-02								PEEK						HL-73004-82		
HL-07003-02	0.58	29.00	2900	5.17	20.68	1/8"	316 SS	PPS	Viton	-45 to 176°C	Yes	10,000	HL-07003-12			
HL-73004-04	1.17	58.50	5850	4.13	20.68	1/8"	316 SS	PEEK	Viton	-45 to 176°C	Yes	10,000	HL-73004-84			
HL-07003-04								PPS						HL-07003-14		

Note: Viscosity for all models is dependent on the parameters (flow rate, pressure, etc.) of the specific applications. Flow rates based on water at room temperature and no back pressure.

MICROPUMP®-COMPATIBLE DRIVES

FEATURES/BENEFITS

- ▶ Console or wall-mount washdown models
- ▶ Easily operate console from front panel or use optional foot switch for hands-free operation
- ▶ Wall-mount washdown drive is ideal for your industrial or dirty locations; the IP56-rated enclosure is connected to motor via 7.6-m (25-ft) cable
- ▶ Calibrate, copy, and dispense features
- ▶ Precise, pulseless batching and dispensing
- ▶ Calibration values for all Micropump® A-mount pump heads are stored in memory
- ▶ Front-panel pump head calibration
- ▶ Digital optical encoder feedback signal keeps speed control to ±0.3%
- ▶ Remote control capabilities
- ▶ Keypad lockout feature

SELECTION CRITERIA

1. Console or wall-mount version.
2. Voltage required.

See specifications for more information.

Order pump heads and drives separately.

DRIVE CONTROLS

- ▶ Controls on front panel of drive controller
- ▶ Lighted display indicates power is on
- ▶ Simple, push-button programming of the following parameters:
 - ◆ Pump SIZE ◆ MODE
 - ◆ DISPense ◆ CALibration
 - ◆ FLOW rate ◆ PRIME
 - ◆ Up/Down (▲▼) ◆ Stop/Start

Note: Up/Down keys are used to change the display value of flow rate and calibration functions during setup or operation.

PUMP HEAD COMPATIBILITY

- ▶ Use with Micropump A-mount pump heads on page 62

DISCONTINUED - NEW MODELS AVAILABLE



Console digital dispensing drive
75211-30



Wall-mount digital dispensing drive
75211-40

NOTES

To calibrate digital dispensing drives for fluids other than water, enter the actual volume of fluid dispensed during a timed run.

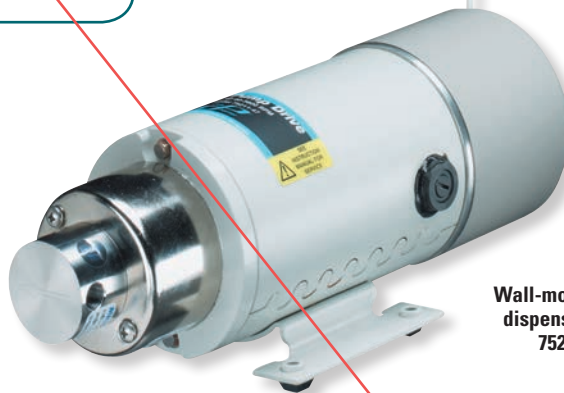

ORDERING INFORMATION

Catalog number	Power (50/60 Hz)
Console digital dispensing drive	
HL-75211-30	115 VAC
HL-75211-35	230 VAC
Wall-mount washdown digital dispensing drive	
HL-75211-40	115 VAC
HL-75211-45	230 VAC

SPECIFICATIONS for Micropump-Compatible Drives

Catalog number	HL-75211-30	HL-75211-35	HL-75211-40	HL-75211-45
Performance Specifications				
Flow capacity	3.06 to 4212 mL/min (0.048 to 67 GPH) [†]		1.02 to 4212 mL/min (0.016 to 67 GPH) [†]	
rpm	180 to 3600		60 to 3600	
Remote control – Input	ON/OFF by contact closure; 0 to 20 mA, 4 to 20 mA, 0 to 10 VDC			
Physical Specifications				
Voltage/Frequency VAC (50/60 Hz)	90 to 130	190 to 260	90 to 130	190 to 260
Current	3 A	1.5 A	3 A	1.5 A
Motor type	1/10-hp, permanent-magnet DC			
IP rating [‡]	IP23		IP56 (NEMA 4X)	
Operating temperature	0 to 40°C (32 to 104°F)			
Dimensions (L x W x H)	Console	29.2 x 19.7 x 18.4 cm (11½" x 7¾" x 7¼")		
	Wall-mount	Controller: 11.4 x 27.9 x 22.9 cm (11½" x 7¾" x 7¼") Drive: 20.3 x 10.2 x 11.4 cm (8" x 4" x 4½")		
Shipping weight	6.4 kg (14 lb)		9.1 kg (20 lb)	

[†]Depending on pump head selected.

[‡]See page 194 for an explanation of IP ratings.

ACCESSORIES

HL-07595-42 Foot switch for remote start/stop control of 75211-30 and -35 drives.

HL-07592-83 Handheld remote controller for use with 75211-40 and -45 drives. Features start/stop, reverse, and momentary on (prime) functions.

Cole-Parmer® CONSOLE DRIVE

FEATURES/BENEFITS

- Permanent-magnet, direct-current (PMDC) motor is built for long-term applications
- Maximum continuous-duty flow rates possible with Micropump® A-mount pump heads on page 62
- Gradual, one-second acceleration for smooth flow rate changes

SELECTION CRITERIA

1. Voltage required.

See specifications for more information.

Order pump heads and drives separately.

DRIVE CONTROLS

- Single-turn potentiometer speed control
- Separate power switch with lighted "power-on" indicator

PUMP HEAD COMPATIBILITY

- Use with Micropump A-mount pump heads on page 62



75211-10

SPECIFICATIONS & ORDERING INFORMATION

ISO9001:2008 CERTIFIED SUPPLIER 2 year warranty

Catalog number	HL-75211-10	HL-75211-15
Performance Specifications		
Flow capacity	0.85 to 5850 mL/min (0.013 to 92.7 GPH)	
rpm	50 to 5000	
Remote control - Input	No	
Physical specifications		
Voltage/Frequency VAC (50/60 Hz)	115	230
Current	2.0	1.0
Motor type	Permanent magnet DC	
IP rating†	IP22	
Operating temperature	0 to 40°C (32 to 104°F)	
Dimensions	21.6 x 16.2 x 13.2 cm (8½" x 6⅜" x 5⅞")	
Shipping weight	5.0 kg (11 lb)	

†See page 194 for an explanation of IP ratings.

Cole-Parmer® MODULAR GEAR PUMP DRIVE

FEATURES/BENEFITS

- Permanent-magnet, direct-current (PMDC) motor is built for long-term applications
- "Soft-start" feature allows gradual, one-second acceleration for smooth flow rate change
- Continuous-duty drives feature 2% line/load regulation
- Controller features IP23-rated housing and single-turn potentiometer for speed control
- IP21-rated motor features a welded base for mounting or for free-standing use. Compatible with all Micropump® A-mount pump heads on page 62.

SELECTION CRITERIA

1. Voltage required.

See specifications for more information.

Order pump heads and drives separately.

DRIVE CONTROLS

- Controls on front panel of drive controller
- Single-turn potentiometer speed control
- Separate power switch with lighted "power-on" indicator

PUMP HEAD COMPATIBILITY

- Use with Micropump A-mount pump heads on page 62



75211-20

SPECIFICATIONS & ORDERING INFORMATION

ISO9001:2008 CERTIFIED SUPPLIER 2 year warranty

Catalog number	HL-75211-20	HL-75211-25
Performance Specifications		
Flow capacity	0.68 to 4212 mL/min (0.01 to 66.6 GPH)	
rpm	40 to 3600	
Remote control - Input	No	
Physical specifications		
Voltage/Frequency VAC (50/60 Hz)	115	230
Current	2.3	1.2
Motor type	Permanent magnet DC	
IP rating†	IP21	
Operating temperature	0 to 40°C (32 to 104°F)	
Dimensions	Controller: 17.3 x 8.3 x 13.4 cm (7" x 3¼" x 5¼") Drive: 17.3 x 12.3 x 9.2 cm (6⅞" x 4⅜" x 3⅝")	
Shipping weight	5.9 kg (13 lb)	

†See page 194 for an explanation of IP ratings.

Cole-Parmer® GEAR PUMP SYSTEMS

FEATURES/BENEFITS

- Complete pump system—drive and pump head—with a single catalog number

BENCHTOP ANALOG PUMPS

- Gradual on-second acceleration offers smooth control of drive speed and flow rate
- PMD drive is built to last—excellent for long-term applications
- System includes analog console drive 75211-10 (115 V) or 75211-15 (230 V); see page 64 for drive specifications

BENCHTOP DIGITAL PUMPS

- Calibrate, copy, and dispense features produce precise, pulseless batching and dispensing
- Displacements and flow values for all Micropump® A-mount pump heads are stored in memory
- IP23-rated enclosure protects the internal components
- Controller has a DB15F connection to the optional foot switch for hands-free on/off control (order foot switch separately below)
- System includes digital console drive 75211-30 (115 V) or 75211-35 (230 V); see page 63 for drive specifications



Benchtop analog pump system 74013-40



Benchtop digital pump system 74014-30

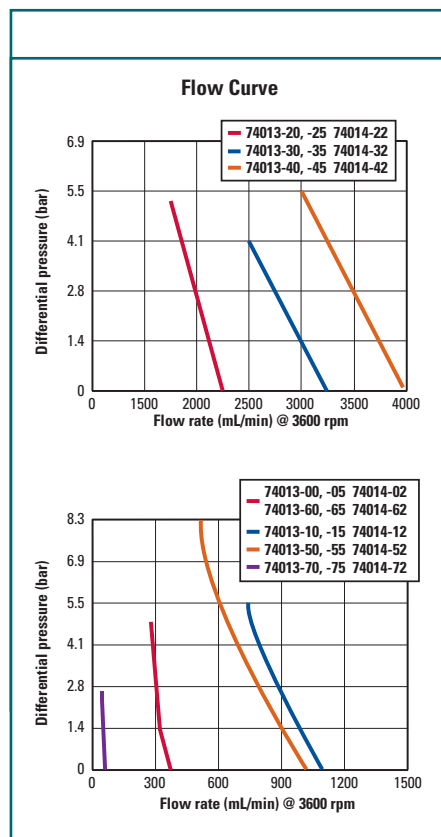

MORE INFO

Service kits 07144-42; 74012-02, -42, and -52 include: gears, suction shoe, shaft seals, and springs.

Service kits 74012-12, -22, and -32 include: gears, bushings, and seals.

SPECIFICATIONS & ORDERING INFORMATION

Viscosity: 0.2 to 1500 cp
Suction lift: 59.8 millibar (24" of H₂O) at 1750 rpm
Duty cycle: continuous

Remote control
 74013-00 to -65: none
 74014-00 to -65: (input) on/off by contact closure 0 to 10 VDC, 0 to 20 mA, 4 to 20 mA, and remote output

Max temperature: 40°C (104°F)

Speed
 Analog drives: 50 to 5000 rpm
 Digital drives: 60 to 3600 rpm

Dimensions (L x W x H)

Analog drives:
 21.6 x 16.2 x 13.8 cm (8½" x 6⅝" x 5½")
Digital drives:
 19.7 x 29.2 x 18.4 cm (7¾" x 11½" x 7¼")

ISO9001:2008
 CERTIFIED SUPPLIER

UL US

CE

2 year warranty

Flow rates (mL/min) [†]			Max pressure		Port size NPT(F)	Wetted parts			Temperature range	Power (VAC)	Benchtop analog pumps	Benchtop digital pumps	Service kits
mL/rev	at 50 rpm	at 3600 rpm	Diff (bar)	System (bar)		Body	Gears	Seals			Catalog number	Catalog number	Catalog number
0.017	0.85	85	1.37	20.68	⅜"	316 SS	Graphite	PTFE	-46 to 177°C (-50 to 350°F)	115	HL-74013-70	HL-74014-70	HL-07144-42
										220	HL-74013-75	HL-74014-75	
0.092	4.60	331.2	5.17	20.68	⅜"	316 SS	PPS	PTFE	-46 to 177°C (-50 to 350°F)	115	HL-74013-00	HL-74014-00	HL-74012-02
										220	HL-74013-05	HL-74014-05	
0.092	4.60	331.2	5.17	20.68	⅜"	316 SS	PPS	PPS	-46 to 177°C (-50 to 350°F)	115	HL-74013-60	HL-74014-60	—
										220	HL-74013-65	HL-74014-65	
0.261	13.05	939.6	8.61	20.68	⅜"	316 SS	PEEK	Viton	-46 to 177°C (-50 to 350°F)	115	HL-74013-50	HL-74014-50	HL-74012-52
										220	HL-74013-55	HL-74014-55	
0.316	15.8	1137.6	5.17	20.68	⅜"	316 SS	PPS	PTFE	-46 to 54°C (-50 to 130°F)	115	HL-74013-10	HL-74014-10	HL-74012-12
										220	HL-74013-15	HL-74014-15	
0.64	32.0	2304	5.17	20.68	⅜"	316 SS	PPS	PTFE	-46 to 54°C (-50 to 130°F)	115	HL-74013-20	HL-74014-20	HL-74012-22
										220	HL-74013-25	HL-74014-25	
0.91	45.5	3276	5.17	20.68	⅜"	316 SS	PPS	PTFE	-46 to 54°C (-50 to 130°F)	115	HL-74013-30	HL-74014-30	HL-74012-32
										220	HL-74013-35	HL-74014-35	
1.17	58.5	4212	4.13	20.68	⅜"	316 SS	PPS	Viton®	-46 to 177°C (-50 to 350°F)	115	HL-74013-40	HL-74014-40	HL-74012-42
										220	HL-74013-45	HL-74014-45	

[†]Flow rates in mL/min are based on water at room temperature and no back pressure.

DISCONTINUED - NEW MODELS AVAILABLE

ACCESSORIES

[HL-07595-42](#) Foot switch, for momentary start/stop control. 6-ft cable.

[HL-06385-10](#) Male pipe adapter (straight); PP, ¼" OD x ⅜" NPT(M). Pack of 10.

[HL-30621-31](#) Male pipe adapter; HDPE, ⅜" NPT(M) x ¼" ID. Pack of 10.

[HL-40610-36](#) Male pipe adapter; natural PP, ⅜" NPT(M) x ¼" ID. Pack of 10.

ISMATEC® MINICARTRIDGE PUMP HEADS



Ismatec®
minicartridge
pump head
07623-00
shown with
Masterflex®
L/S® drive
07528-10

SPECIFICATIONS for Ismatec® Minicartridge Pump Heads

Catalog number	HL-07623-00	HL-07623-10
Performance Specifications		
Flow capacity	0.003 to 195 mL/min (0 to 3 GPH)	0.002 to 156 mL/min (0 to 2.5 GPH)
Max rpm	600	
Number of rollers	6	8
Number of channels available	Up to 8	
Torque Specifications [single channel pumping water @ 0 psi, 21°C (70°F)]		
PharMed® BPT, Tygon®	Starting torque	0.86 kg-cm (12 oz-in)
	Running torque	0.7 kg-cm (10 oz-in)
Silicone	Starting torque	0.5 kg-cm (7 oz-in)
	Running torque	0.2 kg-cm (3 oz-in)
Physical Specifications		
Housing material	Anodized aluminum	
Rotor material	Nylatron®	
Shipping weight	1.9 kg (2 lb)	

FEATURES/BENEFITS

- Deliver flow rates from 0.002 to 195 mL/min
- Click'n'Go™ minicartridges are easy to load and feature spring occlusion
- Optimum tension; no need for adjustments
- Accepts three-stop tubing
- Tubing life is twice as long—when first tubing section fatigues, move to fresh section
- Adapts easily to OEM applications

COMPATIBILITY WITH DRIVES

- Mount on all drives accepting Masterflex® L/S® pump heads

PUMP HEAD SPECIFICATIONS

- Anodized aluminum frame
- Nylatron® rollers
- Nylon minicartridges

PUMP HEAD LOADING

- Thread tubing through cartridge between stops.
- Seat the tubing collar in recessed holder.
- Load cartridge into pump head and adjust occlusion.

MULTICHANNEL CAPABILITIES

Achieve up to eight channels depending on the drive. Minicartridges, mounting hardware, and support foot are included with pump heads.

Masterflex drive models	Recommended no. of channels
HL-07554-80, -85, -90, -95	Up to 200 rpm, 8 Up to 400 rpm, 5 Up to 600 rpm, 3
All other L/S models	Up to 200 rpm, 8 Up to 400 rpm, 7 Up to 600 rpm, 6

SELECTION CRITERIA

- Flow rate.
 - ◆ 6-roller pump head for higher flow rate
 - ◆ 8-roller pump head for smoother flow
- Number of rollers.
- Compatibility with drives.
- Number of channels per drive rpm.

Order tubing and drive separately.



ORDERING INFORMATION

Catalog number	No. of rollers	Flow range
HL-07623-00	6	0.003 to 195 mL/min
HL-07623-10	8	0.002 to 156 mL/min

HL-78016-98 Replacement Click'n'Go™ minicartridge.

THREE-STOP TUBING FLOW RATE & ORDERING INFORMATION

Step 1: See table below for catalog number prefix.

Cat. no. prefix	Three-stop, color-coded tubing			Extension tubing	
	Type	Suffixes for the available sizes	Tubes/pk (length) ¹	Cat. no. prefix	Length/pk
HL-96450-XX	Tygon® E-LFL	10, 12, 18, 26, 30, 34, 42, 48	12 (16")	HL-06449-XX	100 ft
HL-96458-XX	Tygon® E-Food		12 (16")	HL-06457-XX	100 ft
HL-96461-XX	Tygon® E-Lab		12 (16")	HL-06460-XX	100 ft
HL-07624-XX	Silicone (peroxide-cured)	22, 24, 26, 28, 30, 32, 34, 36, 38, 40, 42, 44, 46, 48	6 (16")	HL-07625-XX	50 ft
HL-95603-XX	Silicone (platinum-cured)	22, 24, 26, 28, 30, 32, 34, 36, 38, 40, 42, 44, 46, 48	6 (16")	HL-95612-XX	50 ft
HL-97629-XX	Viton®	26, 30, 34, 38, 42, 46, 48	12 (12")	HL-97632-XX	50 ft
HL-95714-XX	PharMed® BPT	12, 18, 26, 32, 36, 40, 44, 48	12 (16")	HL-95809-XX	100 ft
HL-95693-XX	Autoclavable PharMed® BPT	12, 32, 48	6 (16")	HL-95809-XX	100 ft
HL-95605-XX	PVC Solvent/Hydrocarbon	10, 12, 14, 18, 22, 24, 26, 28, 30, 32, 34, 36, 40, 42, 44, 46, 48	12 (16")	HL-95712-XX	50 ft
HL-96425-XX	MHLL	24, 30, 36, 42, 48	6 (16")	None (PharMed BPT recommended for extension tubing; see 95809-XX above)	

Step 2: Add on suffix to complete the catalog number.

Catalog number suffix	ID (mm)	Color-coded stops	Flow rates (mL/min) ²			
			1 to 100 rpm drives		6 to 600 rpm drives	
			6 rollers	8 rollers	6 rollers	8 rollers
-10	0.19	Orange/red	0.003 to 0.32	0.002 to 0.26	0.030 to 1.2	0.002 to 1.0
-12	0.25	Orange/blue	0.004 to 0.65	0.003 to 0.54	0.007 to 2.7	0.005 to 2.1
-14	0.38	Orange/green	0.008 to 1.1	0.007 to 0.09	0.011 to 4.6	0.009 to 3.6
-16	0.44	Green/yellow	0.012 to 1.6	0.009 to 1.3	0.014 to 5.5	0.011 to 4.4
-18	0.51	Orange/yellow	0.016 to 2.0	0.013 to 1.7	0.017 to 6.9	0.014 to 5.5
-22	0.64	Orange/white	0.025 to 3.1	0.020 to 2.6	0.033 to 20	0.026 to 15
-24	0.76	Black/black	0.030 to 3.9	0.025 to 3.2	0.047 to 28	0.037 to 22
-26	0.89	Orange/orange	0.043 to 5.4	0.036 to 4.5	0.060 to 36	0.048 to 39
-28	1.02	White/white	0.058 to 7.0	0.048 to 5.9	0.082 to 4.9	0.065 to 39
-30	1.14	Red/red	0.072 to 8.6	0.060 to 7.2	0.088 to 53	0.071 to 42
-32	1.30	Gray/gray	0.079 to 10	0.066 to 8.6	0.11 to 67	0.089 to 54
-34	1.42	Yellow/yellow	0.086 to 12	0.072 to 9.9	0.14 to 81	0.11 to 65
-36	1.52	Blue/blue	0.10 to 14	0.084 to 11	0.14 to 85	0.11 to 68
-38	1.65	Blue/blue	0.12 to 15	0.096 to 13	0.17 to 103	0.14 to 82
-40	1.85	Green/green	0.16 to 20	0.13 to 16	0.20 to 121	0.16 to 97
-42	2.06	Purple/purple	0.19 to 23	0.16 to 19	0.23 to 136	0.18 to 109
-44	2.29	Purple/black	0.20 to 24	0.17 to 20	0.24 to 148	0.20 to 118
-46	2.54	Purple/orange	0.23 to 29	0.19 to 24	0.29 to 173	0.23 to 138
-48	2.79	Purple/white	0.26 to 32	0.22 to 27	0.32 to 195	0.26 to 156

¹Length of assembly may vary by ±1".

²Flow rates (mL/min) are nominal. Actual flow rates will depend on occlusion, fluid viscosity, pressure, etc.



VALVELESS PISTON PUMP HEADS

FEATURES/BENEFITS

- Deliver flow rate from 0.08 to 432 mL/min
- Ideal for dispensing and metering
- No valves to clog or wear
- Sensitive mechanical stroke length adjustment is accurate to within ±1%
- Maximum viscosity: 500 centipoise
- Maximum pressure: 6.9 bar (100 psi)
- Low dead volume; self-priming
- 3A-approved sanitary models available
- Build your own pump systems using interchangeable heads, drives, and accessories

SELECTION CRITERIA

1. Flow rate.
2. Piston diameter.
3. Construction material.

Order pump head, adapter kit, drive, and tubing separately.

COMPATIBILITY WITH DRIVES

- Mount on Masterflex® L/S® drives using optional Adapter Kit
- Depending on setup, drive may need to be elevated for proper adapter use.

PUMP HEAD SPECIFICATIONS

Stainless steel (SS) and ceramic models

- Handle temperatures to 177°C (350°F)
- Kynar® PVDF cylinder body available



MASTERFLEX® L/S® ADAPTER KIT

This adapter kit is required to convert your L/S drive for use with these valveless piston pump heads. Pump heads have adjustable stroke length to adjust flow rate, allowing you to convert your fixed-speed drive into a variable-flow pump.



Mounting hardware included in the adapter kit.

Catalog number	Description	Includes
HL-07104-48	Masterflex L/S adapter kit	All necessary mounting hardware and fittings

ORDERING INFORMATION for Valveless Piston Pump Heads

Catalog number	Max flow rate (mL/min) at various rpm (vary flow rate by adjusting rpm or stroke length)		Max bar	Max temperature	Piston diameter	Materials of construction			Shpg wt kg (lb)
	1 to 100 rpm	6 to 600 rpm				Piston	Cylinder body	Cylinder liner	
Standard high-flow pump heads									
HL-07104-50	0.08 to 8.00	0.48 to 48.00	6.8	60°C (140°F)	1/8"	316 SS	316 SS	Carbon	0.6 (1.3)
HL-07104-52			4.1				Kynar PVDF		0.3 (0.7)
HL-07117-26	0.32 to 32.00	1.92 to 192.00	4.1	60°C (140°F)	1/4"	316 SS	Kynar PVDF	Carbon	0.4 (0.8)
HL-07104-62			6.8				316 SS		0.5 (1.1)
HL-07104-54	0.32 to 32.00	1.92 to 192.00	4.1	100°C (212°F)	1/4"	Ceramic	Kynar PVDF	Ceramic	0.4 (0.8)
HL-07104-58			6.8				316 SS		0.6 (1.2)
HL-07104-56	0.32 to 32.00	1.92 to 192.00	6.8	177°C (350°F)	1/4"	Ceramic	316 SS	Ceramic	0.6 (1.2)
HL-07104-60			4.1				Kynar PVDF		0.5 (1.1)
HL-07117-28	0.72 to 72.00	4.32 to 432.00	4.1	60°C (140°F)	3/8"	316 SS	Kynar PVDF	Carbon	0.5 (1.1)
HL-07104-72			6.8				316 SS		0.5 (1.1)
HL-07104-64	0.72 to 72.00	4.32 to 432.00	4.1	100°C (212°F)	3/8"	Ceramic	Kynar PVDF	Ceramic	0.4 (0.8)
HL-07104-68			6.8				316 SS		0.5 (1.1)
HL-07104-66	0.72 to 72.00	4.32 to 432.00	6.8	177°C (350°F)	3/8"	Ceramic	316 SS	Ceramic	0.5 (1.1)
HL-07104-70			4.1				316 SS		0.5 (1.1)
Sanitary high-flow pump heads; meet 3A Sanitary Standard 02-08A1 for use with foods									
HL-07117-20	0.32 to 32.00	1.92 to 192.00	6.8	177°C (350°F)	1/4"	Ceramic	316 SS	Ceramic	0.5 (1.1)
HL-07117-22	0.72 to 72.00	4.32 to 432.00			3/8"				

ACCESSORIES

Kynar® PVDF Tubing Adapters
(for 1/4" OD compression fittings)

Cat. no. (each)	Description
HL-07115-81	For 1/8" ID tubing
HL-07115-83	For 1/4" ID tubing
HL-07115-88	For 3/8" ID tubing
HL-07115-89	For 1/4"-28 female thread
HL-07115-97	For 1/8" OD tubing



L/S® TUBING
L/S® DRIVES
L/S® PUMP SYSTEMS.....

ACCESSORIES.....

TECHNICAL DATA.....