

Arcmed



Diba

Omnifit

BIO·CHEM

Solenoid Operated Pinch Valves



BIO·CHEM
FLUIDICS

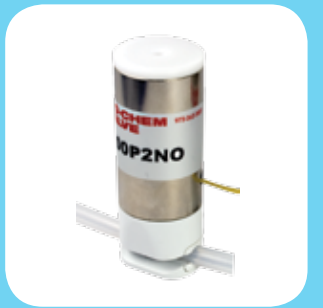







TABLE OF CONTENTS

Page 2	Pinch Valves General Information	
Page 3	Features of the Bio-Chem Valve™ Pinch Valve Contoured body, choice of de-energized state, choice of tubing materials	
Page 4	Pinch Valve Applications Prevention of shear, handling non-liquid effluents	
Page 5	Pinch Valve Selection Guide	
Page 6	075P Series Pinch Valves For use with soft-walled tubing with inner diameters from 0.010"/0.3mm to 1/16"/1.6mm	
Page 9	100P Series Pinch Valves For use with soft-walled tubing with inner diameters from 1/32"/0.8mm to 1/8"/3.2mm	
Page 12	108P Series Multi-Tubing Pinch Valves For use with soft-walled tubing with inner diameters of 1/32"/0.8mm (simultaneous operation of 4, 6 or 8 tubes)	
Page 13	Tubing & Valve Options	
Page 14	Optical Position Feedback Sensor & CoolCube™ "Hit and Hold" Circuit	
Page 15	Mounting Options & Accessories	

PINCH VALVES GENERAL INFORMATION

What is a Pinch Valve?

The Bio-Chem Valve™ Pinch Valve is a solenoid-operated device. It is designed to open and close tubing to achieve controlled fluid flow.

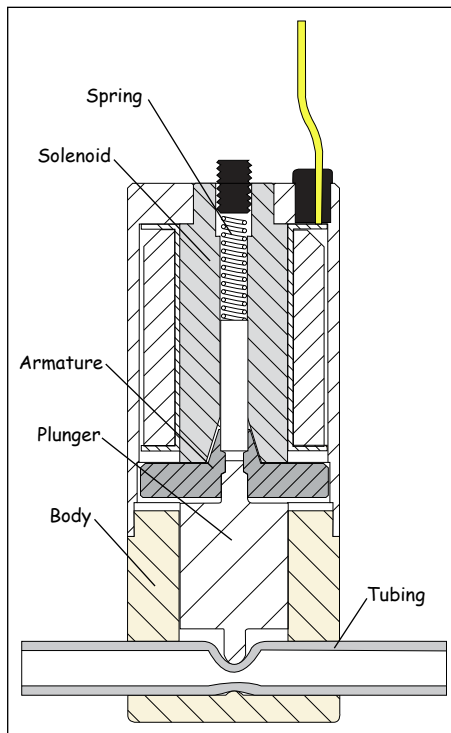

Only the inside of the tubing contacts the fluid. Energizing the solenoid retracts the valve plunger. This either opens the tubing (in the normally closed configuration, as shown left) or closes the tubing (normally open configuration). De-energizing the solenoid allows a spring to push the plunger back to its original position. This returns the tubing to its original closed or open position. A 3-way valve has both a normally open and a normally closed flow path, which are operated simultaneously. The

tubing is held in place by the plunger and precisely sized grooves in the valve body.

Why choose a Pinch Valve?

There are many reasons to use Bio-Chem Valve™ Pinch Valves (refer to page 3 for more details) but pinch valves themselves have specific features that lend themselves to particular applications:

- **Unobstructed flow path.** Pinch valves create minimal pressure drop, which is important for controlling downstream instrumentation. Unobstructed flow is also important when handling fluids that might shear when forced to flow through complex valve internals (for more details see page 4).
- **Tubing is soft yet durable.** Pinch valves are highly tolerant of particulates in the fluid stream (for more details see page 4).
- **Tubing is easy to change.** The user can change tubes if a sterile fluid path is required (for instance, blood collection) or when chemicals create clogs (for instance, system waste lines).
- **Zero dead volume.** Consecutive samples are not contaminated by the previous one.
- **Fluid contacts tubing only.** The materials of construction of the body and plunger do not have to be highly corrosion resistant, which means pinch valves are often very economical when compared to alternatives.
- **Simple.** Pinch valves do not require complicated electronic controls - they are either energized or not. Pinch valves do support the use of "Hit and Hold" circuits which significantly reduce the power required to hold the valve in its energized position (for more detail see the CoolCube™ on page 14).

Features of Bio-Chem Valve™ Pinch Valves

Contoured Body

Bio-Chem Valve™ Pinch Valves incorporate a contoured body which is designed to meet the market demand for better looking and easier to use valves. The contoured body features a smooth profile and enhanced aesthetics with features that benefit not only instrument designers but also the system end-user.

Choice of de-energized state

Bio-Chem Valve™ Pinch Valves are supplied in the following standard configurations:

- 2-way normally closed
- 2-way normally open
- 3-way (where one tube, or set of tubes, is normally open and the other normally closed. When the valve is energized the operation is reversed so the normally open tube is closed and the normally closed tube is opened)

Dual tubing configurations (i.e. two tubes being operated simultaneously) are offered for smaller tubing sizes. Multi-tube pinch valves with 4, 6 or 8 tubes and normally open operation are also available.



2-way
Normally Closed



2-way
Normally Open



3-way

Choice of tubing materials

Bio-Chem Fluidics offers two high-purity medical grade tubing materials for pinch valves:

- Platinum cured silicone tubing
- C-Flex® tubing

Bio-Chem Valve™ Pinch Valves can also be configured to use customer supplied tubing, within a recommended durometer range of 45-60 Shore A.

Easy tube insertion

The tubing entry area of the valve body is contoured to guide the tubing into its seat.

Tubing securely seated

Molded grooves hold the tubing securely in the proper position. The gap between the valve plunger and the valve's anvil is slightly smaller than the tubing's outer diameter. The tubing is held in place during operation without need for mechanical locking features. Fluid flow and pressure drop are minimally affected, achieving approx. 95% of full flow given the nominal tubing inner diameter.



Valve body is contoured to aid tube insertion. Grooved insert clearly identifies the tubing size.

Continuous duty

Bio-Chem Valve™ Pinch Valves can remain in the fully energized state indefinitely without damage to the valve or the tubing.

Low power consumption

The pinch valves' efficient construction permits the use of low wattage solenoid coils, ranging from 2.8 Watt for 075-series valves to 8.1 Watt for 100-series valves, which in turn minimizes heat generation. Both power usage and heat generation can be lowered further by stepping down the voltage after actuation by using a CoolCube™ "Hit and Hold" circuit (refer to page 14 for more details).

Pinch Valve Applications

Prevention of shear in sensitive materials

Pinch Valves are typically used in “on-off” applications; applications that don’t require flow control or modulation – you just want to start and stop the flow.

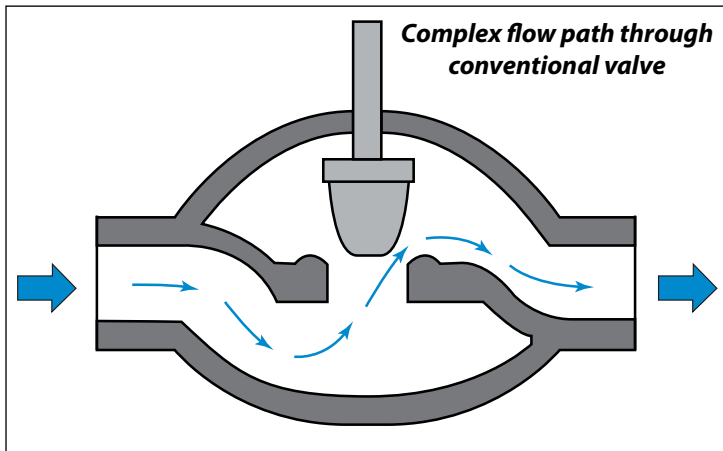

Conventional on-off valves often require the fluid to be regulated to move through a convoluted / complex flow path, even when fully open. This can be an issue for biological materials (proteins, DNA, etc) which can be easily “sheared” when forced through complicated paths.

Pinch Valves offer “line-of-sight” flow paths where the open tube, even if slightly pinched does not significantly block the flow path. Because of the slight venturi effect produced by the pinch, flow through the tubing can actually be enhanced rather than restricted.

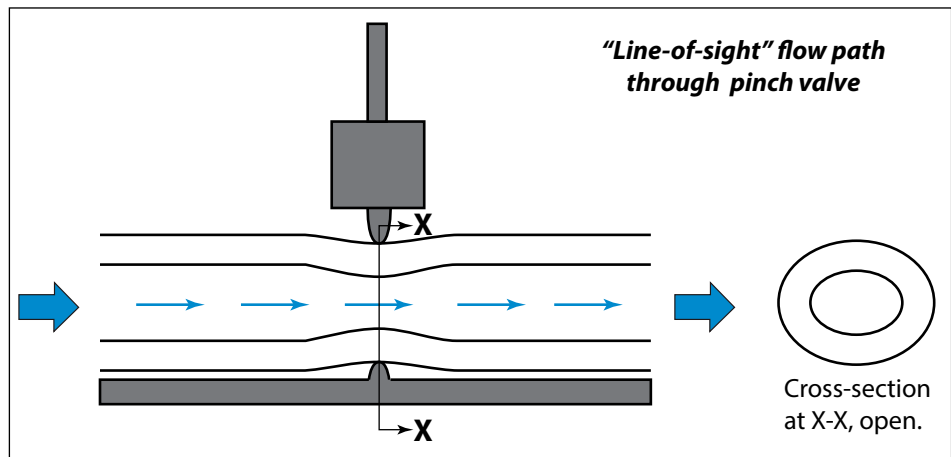

Handling of non-liquid effluents

Pinch Valves are often used on the waste side of instrumentation, “dumping” solutions to a collection device or simply out of the instrument. The waste stream can have many components; liquid, particulates, precipitates and coagulations inadvertently formed from mixtures of chemicals. These accumulated non-liquids can lead to coating on the inner surface of a conventional valve. The coating process is uneven and can eventually lead to the valve becoming clogged.

Pinch Valves offer a three-fold solution to this problem:

1. The tubing can be pre-treated to prevent the build-up of films. Bio-Chem Valve™ silicone tubing is Platinum cured which significantly reduces the possibility of film build-up.
2. The tubing is subjected to a very hard squeeze when the valve is closed. This squeeze is particularly effective in removing any film build-up
3. If the tubing does become blocked – it can quickly and easily be replaced without having to remove the valve from service.

CUSTOMIZED SOLUTIONS

We understand that many applications require customized solutions. Our design and prototyping expertise enables us to offer simple modifications of standard products as well as completely customized designs. Many of the pinch valves we sell are customized to one extent or another. Customizable options include (but are not limited to):

- Materials of construction
- Customer supplied tubing
- Mounting options
- Tagging / labeling
- Length and/or style of connecting leads
- Electrical connections

We look forward to working with you to meet your design engineering objectives!

Pinch Valve Selection Guide

Valves with Bio-Chem Valve™ silicone or C-Flex® tubing

1. Select the tubing material – either silicone or C-Flex®. (See page 13 for additional information about these tubing material options.)
2. Choose your required tubing internal diameter or flow rate, then flow configuration - normally closed (NC), normally open (NO), 3-way or multi-tube
3. Turn to the pages indicated to see full details and ordering information for each valve.

Silicone Tubing

Tubing designation	Internal diameter	Flow configuration			
		2-way NC	2-way NO	3-way	2 or 3-way dual tube
10S	0.010" / 0.3mm	075P2NC (pg. 6)	075P2NO (pg. 6)		
23S	0.023" / 0.6mm				
01S	1/32" / 0.8mm			075P3MP (pg. 7)	
50S	0.050" / 1.3mm				
02S	1/16" / 1.6mm				
01S	1/32" / 0.8mm	100P2NC (pg. 9)	100P2NO (pg. 9)	100P3MP (pg. 10)	100PD (pg. 10)
02S	1/16" / 1.6mm				
03S	1/16" / 1.6mm				
05S	1/8" / 3.2mm			100P3MP (pg. 10)	

C-Flex® tubing

Tubing designation	Internal diameter	Flow configuration			
		2-way NC	2-way NO	3-way	2 or 3-way dual tube
03B	1/16" / 1.6mm	100P2NC (pg. 9)	100P2NO (pg. 9)		
05B	1/8" / 3.2mm			100P3MP (pg. 10)	

Valves for customer-specific tubing

If the customer intends to use the pinch valves with tubing other than Bio-Chem Fluidics-supplied tubing, this can be easily accommodated. The customer should provide a sample of tubing to Bio-Chem Fluidics, who will select the appropriate valve size and adjust the stroke and force settings to match the tubing diameter and durometer.

Bio-Chem Fluidics will assign a special part number to this valve - contact us for more details.

Polymers referenced in this brochure:

ASA/PC = acrylonitrile styrene acrylate / polycarbonate
 PPS = polyphenylene sulfide
 POM = polyoxymethylene (Acetal resin)
 PEEK = polyetheretherketone

Trademarks

C-Flex® is a registered trademark of Saint-Gobain Performance Plastics.
 CoolCube™ is a trademark of Bio-Chem Fluidics Inc.
 Bio-Chem Valve™ is a trademark of Bio-Chem Fluidics Inc.

075P SERIES PINCH VALVES

For use with soft-walled tubing with inner diameters from 0.010"/0.3mm to 1/16"/1.6mm

- Continuous duty solenoid operated valve. Can remain fully energized for indefinite time period
- Precise stroke and closing force setting to protect tubing and extend valve life
- Chemically resistant PPS plunger and ASAPC body materials
- 24" (610mm) lead wires
- Low power consumption (3.6 Watts or less) and minimal heat generation



075P2NC (2-way Normally Closed)



075P2NO (2-way Normally Open)



075P3 (3-way)

NOTE:

1. For 24 VDC, replace 075P2Nx12 with 075P2Nx24 (or for a 3-way valve replace 075P3MP12 with 075P3MP24) in any of the part numbers listed.

A. 2-way normally closed valves

PART NO.	INNER DIAMETER inch/mm	OUTER DIAMETER inch/mm	MIN PRESSURE inHg vac.	MAX PRESSURE psi/bar	POWER AT 21°C Watts
12 VDC valves with silicone tubing, 12" (305mm) length of silicone tubing is installed in the valve ¹.					
075P2NC12-10S	0.010 / 0.3	0.093 / 2.4	28.2	30 / 2.0	2.9
075P2NC12-23S	0.023 / 0.6	0.093 / 2.4	28.2	20 / 1.3	2.9
075P2NC12-01S	1/32 / 0.8	3/32 / 2.4	28.2	15 / 1.0	2.9
075P2NC12-50S	0.050 / 1.3	0.134 / 3.4	28.2	15 / 1.0	3.6
075P2NC12-02S	1/16 / 1.6	1/8 / 3.2	28.2	15 / 1.0	2.9

B. 2-way normally open valves

PART NO.	INNER DIAMETER inch/mm	OUTER DIAMETER inch/mm	MIN PRESSURE inHg vac.	MAX PRESSURE psi/bar	POWER AT 21°C Watts
12 VDC valves with silicone tubing, 12" (305mm) length of silicone tubing is installed in the valve ¹.					
075P2NO12-10S	0.010 / 0.3	0.093 / 2.4	28.2	30 / 2.0	2.9
075P2NO12-23S	0.023 / 0.6	0.093 / 2.4	28.2	20 / 1.3	2.9
075P2NO12-01S	1/32 / 0.8	3/32 / 2.4	28.2	15 / 1.0	2.9
075P2NO12-50S	0.050 / 1.3	0.134 / 3.4	28.2	15 / 1.0	3.6
075P2NO12-02S	1/16 / 1.6	1/8 / 3.2	28.2	15 / 1.0	2.9

075P SERIES PINCH VALVES continued

C. 3-way valves (one port normally open, other port normally closed) ¹

PART NO.	INNER DIAMETER inch/mm	OUTER DIAMETER inch/mm	MIN PRESSURE inHg vac.	MAX PRESSURE psi/bar	POWER AT 21°C Watts
12 VDC valves with silicone tubing, two 6" (152mm) lengths of silicone tubing joined by 'Y' connector installed in the valve.					
075P3MP12-23S	0.023 / 0.6	0.093 / 2.4	28.2	20 / 1.3	3.6
075P3MP12-01S	1/32 / 0.8	3/32 / 2.4	28.2	15 / 1.0	3.6
075P3MP12-50S ²	0.050 / 1.3	0.134 / 3.4	28.2	15 / 1.0	3.6
075P3MP12-02S	1/16 / 1.6	1/8 / 3.2	28.2	15 / 1.0	3.6

NOTES:

- The operation of 3-way valves can be compromised by extended continuous operation. A "Hit and Hold" circuit is strongly recommended to reduce heat generation in extended use applications.
- 075P3MP12-50S Pinch Valve is not molded



From left to right: 100P3 (3-way), 100PD2NC (2-way Normally Closed, Dual Tubing), 075P2NO (2-way Normally Open), 100P2NC (2-way Normally Closed), 075P2NO (2-way Normally Open), 100P2NO (2-way Normally Open), 075P3 (3-way), 108P (Multi-tubing)

075P SERIES PINCH VALVES continued

INSTALLATION DRAWINGS

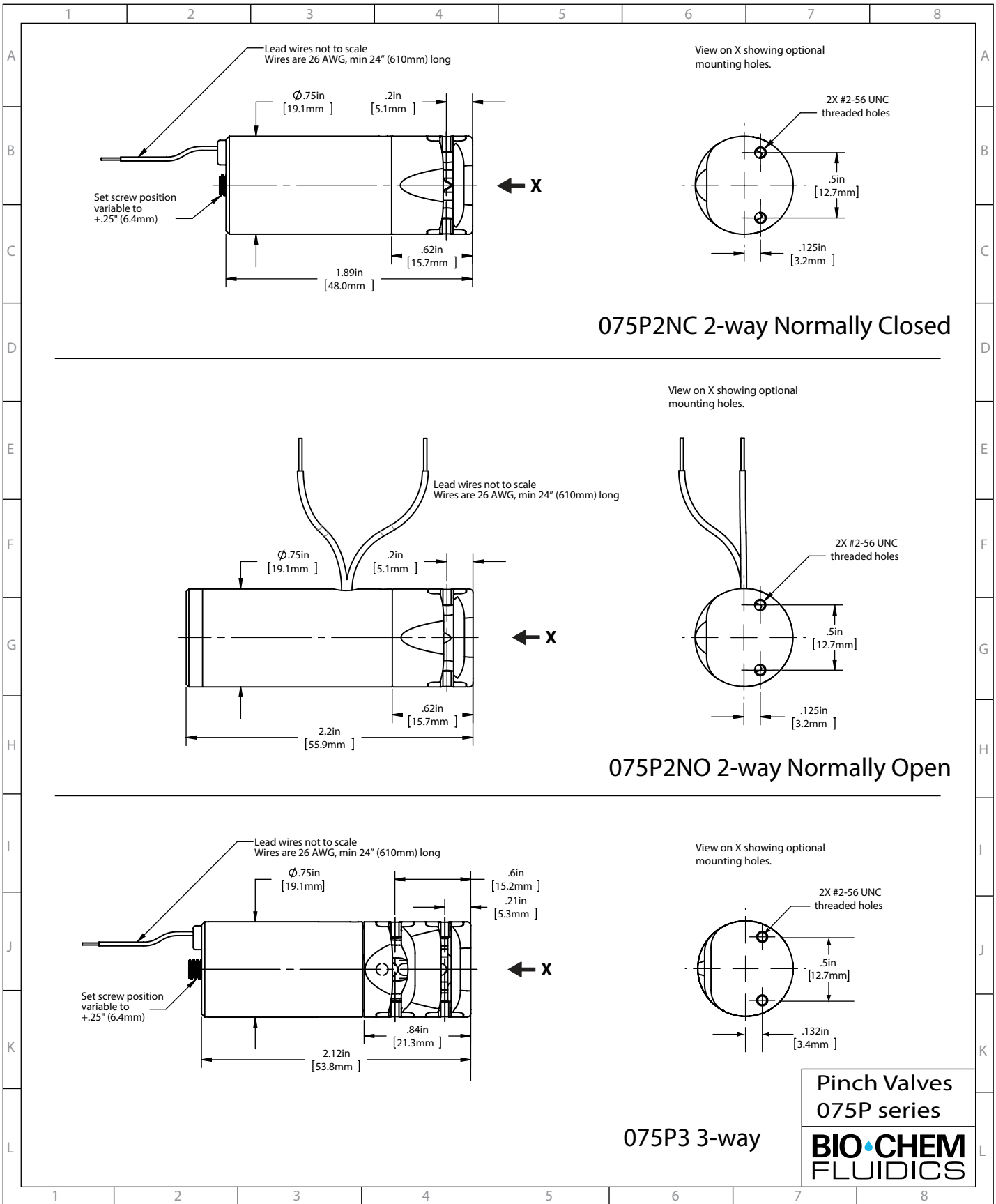

100P SERIES PINCH VALVES

For use with soft-walled tubing with inner diameters from 1/32"/0.8mm to 1/8"/3.2mm

- Continuous duty solenoid operated valve. Can remain fully energized for indefinite time period
- Precise stroke and closing force setting to protect tubing and extend valve life
- Chemically resistant PPS plunger and ASA/PC body materials (unless otherwise noted)
- 24" (610mm) lead wires
- Low power consumption (mostly 4.0 Watts) and minimal heat generation



100P2NC (2-way Normally Closed)



100P2NO (2-way Normally Open)



100P3 (3-way)

NOTE:

1. For 24 VDC, replace 100P2Nx12 with 100P2Nx24 (or for a 3-way valve replace 100P3MP12 with 100P3MP24) in any of the part numbers listed.

A. 2-way normally closed valves

PART NO.	INNER DIAMETER inch/mm	OUTER DIAMETER inch/mm	MIN PRESSURE inHg vac.	MAX PRESSURE psi/bar	POWER AT 21°C Watts
12 VDC valves with silicone tubing, 12" (305mm) length of silicone tubing is installed in the valve ¹.					
100P2NC12-01S	1/32 / 0.8	3/32 / 2.4	28.2	25 / 1.6	4.0
100P2NC12-02S	1/16 / 1.6	1/8 / 3.2	28.2	25 / 1.6	4.0
100P2NC12-03S	1/16 / 1.6	3/16 / 4.8	28.2	25 / 1.6	4.0
100P2NC12-05S	1/8 / 3.2	1/4 / 6.4	28.2	20 / 1.3	4.0
12 VDC valves with C-Flex® tubing, 12" (305mm) length of C-Flex® tubing is installed in the valve.					
100P2NC12-05B	1/8 / 3.2	1/4 / 6.4	28.2	20 / 1.3	4.0

B. 2-way normally open valves

PART NO.	INNER DIAMETER inch/mm	OUTER DIAMETER inch/mm	MIN PRESSURE inHg vac.	MAX PRESSURE psi/bar	POWER AT 21°C Watts
12 VDC valves with silicone tubing, 12" (305mm) length of silicone tubing is installed in the valve ¹.					
100P2NO12-01S	1/32 / 0.8	3/32 / 2.4	28.2	25 / 1.6	4.0
100P2NO12-02S	1/16 / 1.6	1/8 / 3.2	28.2	25 / 1.6	4.0
100P2NO12-03S	1/16 / 1.6	3/16 / 4.8	28.2	25 / 1.6	4.0
100P2NO12-05S	1/8 / 3.2	1/4 / 6.4	28.2	20 / 1.3	4.0
12 VDC valves with C-Flex® tubing, 12" (305mm) length of C-Flex® tubing is installed in the valve.					
100P2NO12-05B	1/8 / 3.2	1/4 / 6.4	28.2	20 / 1.3	4.0

C. 3-way valves (one port normally open, other port normally closed) ¹

PART NO.	INNER DIAMETER inch/mm	OUTER DIAMETER inch/mm	MIN PRESSURE inHg vac.	MAX PRESSURE psi/bar	POWER AT 21°C Watts	PART NO.	INNER DIAMETER inch/mm	OUTER DIAMETER inch/mm	MIN PRESSURE inHg vac.	MAX PRESSURE psi/bar	POWER AT 21°C Watts
12 VDC valves with silicone tubing, two 6" (152mm) lengths of silicone tubing joined by 'Y' connector installed in the valve.						12 VDC valves with silicone tubing, two 6" (152mm) lengths of C-Flex® tubing joined by 'Y' connector installed in the valve.					
100P3MP12-01S	1/32 / 0.8	3/32 / 2.4	28.2	25 / 1.6	4.0	100P3MP12-05B	1/8 / 3.2	1/4 / 6.4	28.2	20 / 1.3	8.1
100P3MP12-02S	1/16 / 1.6	1/8 / 3.2	28.2	25 / 1.6	4.0						
100P3MP12-05S	1/8 / 3.2	1/4 / 6.4	28.2	20 / 1.3	8.1						

D. Valves with dual tubing

For use with soft-walled tubing with inner diameters of 1/32" / 0.8mm and 1/16" / 1.6mm.

Features of standard 100PD series dual-tubing pinch valves are identical to those of single-tubing pinch valves except:

- The body and plunger material is POM
- There are two sets of tubing in every valve



100PD2NC (2-way Normally Closed, Dual tubing)

NOTE:

1. For 24 VDC, replace 100PD2Nx12 with 100PD2Nx24 (or for a 3-way valve replace 100PD3MP12 with 100PD3MP24) in any of the part numbers listed.

PART NO.	INNER DIAMETER inch/mm	OUTER DIAMETER inch/mm	MIN PRESSURE inHg vac.	MAX PRESSURE psi/bar	POWER AT 21°C Watts
2-way normally closed 12 VDC valves with silicone tubing, two 12" (305mm) lengths of silicone tubing are installed in the valve .					
100PD2NC12-01S	1/32 / 0.8	3/32 / 2.4	28.2	25 / 1.6	4.0
100PD2NC12-02S	1/16 / 1.6	1/8 / 3.2	28.2	25 / 1.6	4.0
2-way normally open 12 VDC valves with silicone tubing, two 12" (305mm) lengths of silicone tubing are installed in the valve .					
100PD2NO12-01S	1/32 / 0.8	3/32 / 2.4	28.2	25 / 1.6	4.0
100PD2NO12-02S	1/16 / 1.6	1/8 / 3.2	28.2	25 / 1.6	4.0
3-way 12 VDC valves with silicone tubing, four 6" (152mm) lengths of silicone tubing joined by 'Y' connectors installed .					
100PD3MP12-01S	1/32 / 0.8	3/32 / 2.4	28.2	25 / 1.6	4.0
100PD3MP12-02S	1/16 / 1.6	1/8 / 3.2	28.2	25 / 1.6	4.0

NOTES:

1. The operation of 3-way valves can be compromised by extended continuous operation. A "Hit and Hold" circuit is strongly recommended to reduce heat generation in extended use applications.

100P SERIES PINCH VALVES continued

INSTALLATION DRAWINGS

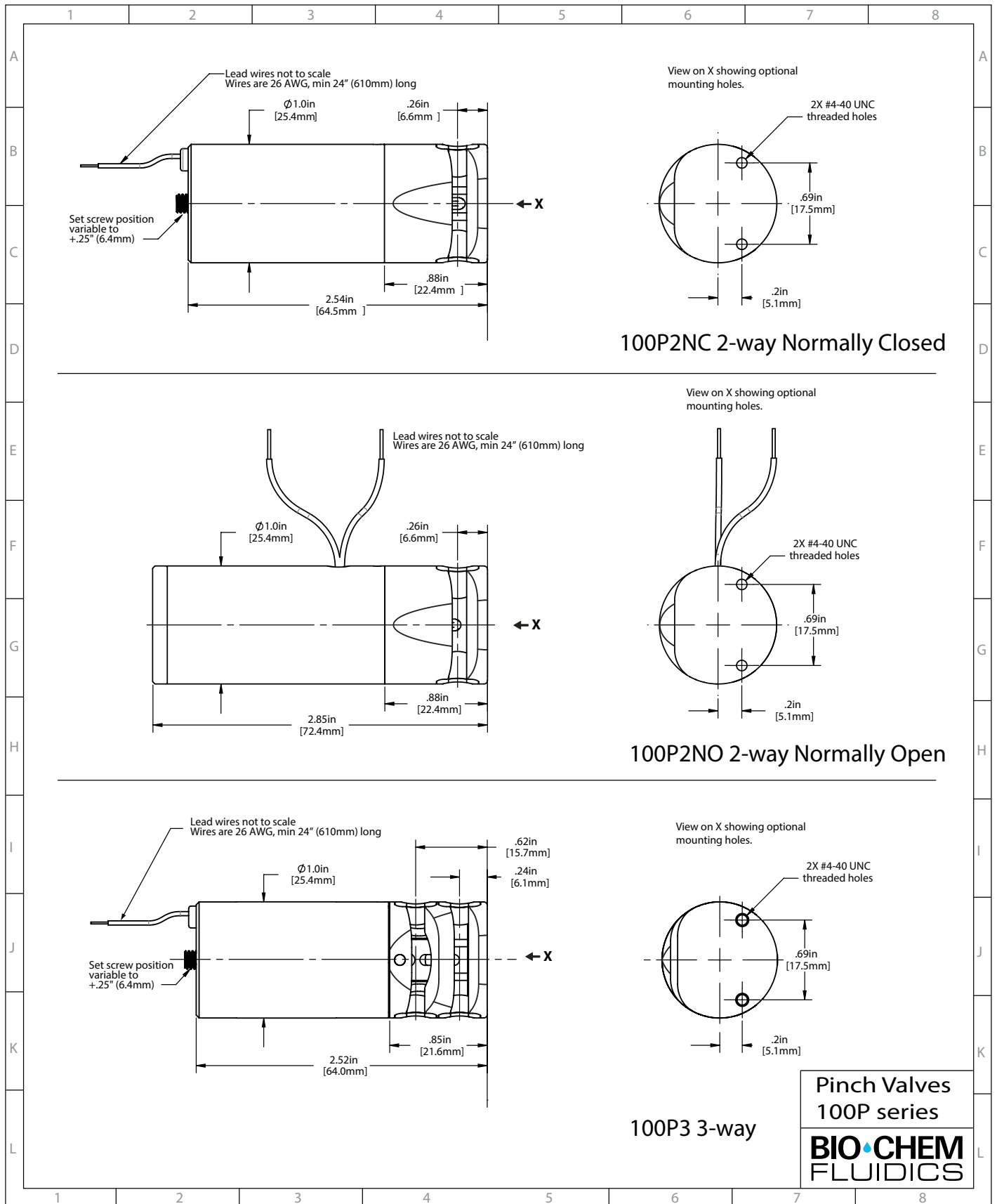

Installation drawings for 100PD series are available on request.

108P SERIES MULTI-TUBING PINCH VALVES

For use with soft-walled tubing with inner diameter of $\frac{1}{32}$ " / 0.8mm. Simultaneous operation of 4, 6 or 8 tubes.

- Continuous duty solenoid operated valve. Can remain fully energized for indefinite time period
- Precise stroke and closing force setting to protect tubing and extend valve life
- Chemically resistant PEEK plunger and POM body materials
- 15-inch (38cm) lead wires
- Low power consumption (3.5 Watts) and minimal heat generation
- Integrated flange with mounting holes
- Stainless steel push bar
- C-Flex® tubing (silicone tubing is not available for this pinch valve series)

Contact us today for availability at Questions@ArcmedGroup.com



INSTALLATION DRAWINGS

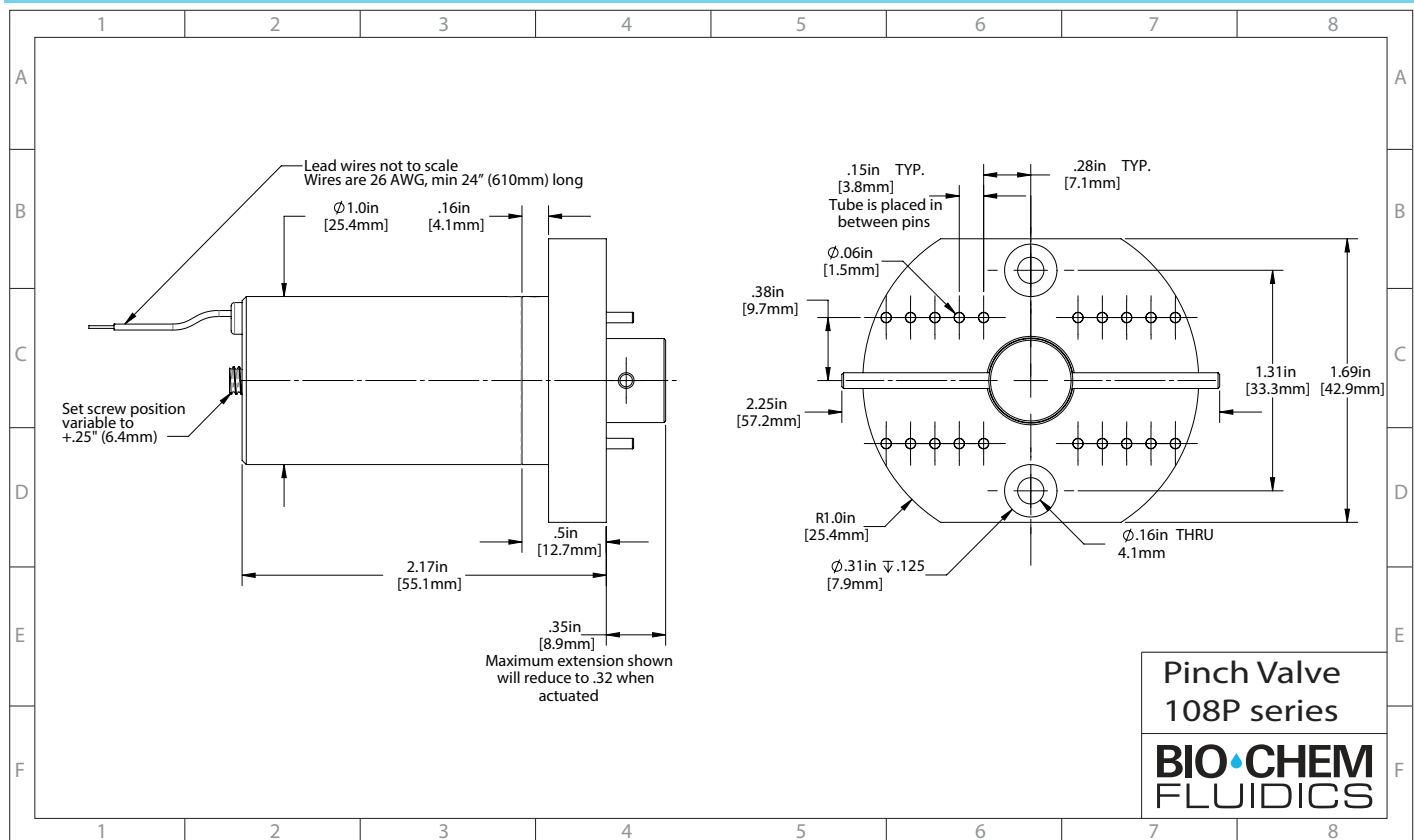

TUBING FOR BIO-CHEM VALVE™ PINCH VALVES

Tubing is extremely durable and has been specifically selected for use with pinch valves. Platinum curing performed on the tubing during the extrusion process imparts superior strength and durability. Silicone tubing can be sterilized through steam autoclaving, boiling, dry heat, and gamma radiation and has a poor gas permeability rating. (Part nos. below refer to 50 ft./15.2 m. coils)

	Part Number	Diameter		Pressure		Nominal Durometer* * Shore A
		Inner	Outer	Minimum	Maximum	
		Platinum-cured silicone tubing	10025-10S	0.010"/0.3mm	0.093"/2.4mm	
	10025-23S	0.023"/0.6mm	0.093"/2.4mm	28.2 inHg vac.	20 psi / 1.3 bar	60
	10025-01S	1/32"/0.8mm	3/32"/2.4mm	28.2 inHg vac.	25 psi / 1.6 bar	60
	10025-50S	0.05"/1.3mm	0.134"/3.4mm	28.2 inHg vac.	15 psi / 1.0 bar	60
	10025-02S	1/16"/1.6mm	1/8"/3.2mm	28.2 inHg vac.	25 psi / 1.6 bar	50
	10025-03S	1/16"/1.6mm	3/16"/4.8mm	28.2 inHg vac.	25 psi / 1.6 bar	50
	10025-05S	1/8"/3.2mm	1/4"/6.4mm	28.2 inHg vac.	20 psi / 1.3 bar	50

C-Flex® tubing is tested in accordance to the standards set by the United States Pharmacopoeia National Formulary XVII, 1990, Class VI Biological Test for Plastics. It is FDA Master file listed.

C-Flex® tubing is made from a thermoplastic elastomer based on styrene-ethylene-butylene and can be used with many acids and alkalis. This tubing is extremely durable and has been specifically selected for use with pinch valves. C-Flex® tubing can be sterilized through steam autoclaving, ethylene oxide (ETO), and gamma radiation and has a fair gas permeability rating. (Part nos. below refer to 50 ft./15.2 m. coils)

	Part Number	Diameter		Pressure		Nominal Durometer* * Shore A
		Inner	Outer	Minimum	Maximum	
		C-Flex® tubing	10025-03B	1/16"/1.6mm	3/16"/4.8mm	
	10025-05B	1/8"/3.2mm	1/4"/6.4mm	28.2 inHg vac.	20 psi / 1.3 bar	50

AVAILABLE OPTIONS FOR BIO-CHEM VALVE™ PINCH VALVES

A variety of options are available on the standard pinch valve. Contact us for more details on how to order.

1. **"Quiet" operation.** The quiet option reduces the valve noise level from about 72 dB (A) to less than 50 dB (A). The quiet option is available for 075P2NC & 100P2NC 2-way normally closed valves and 075P2NO & 100P2NO 2-way normally open valves.

The quiet option is not available on 075P3MP & 100P3MP 3-way valves or 108P multi-tubing valves.

2. **Mounting holes.** Threaded holes situated on the bottom of the valve body. Refer to installation drawings on pages 8 and 11 for details and dimensions for 075P and 100P valves. 108P valves have mounting holes as standard.

3. **Position feedback sensor.** The feedback sensor provides secondary, independent confirmation of the plunger position (more details on page 14). The feedback option is available for 075P2NC & 100P2NC 2-way normally closed valves, 075P3MP & 100P3MP 3-way valves and 100PD dual tubing valves.

4. **Factory-installed mounting flange.** The mounting flanges are available for all pinch valve configurations. They will be installed at a 90° angle to the tubing with the orientation to the outside of the bulkhead.

This mounting flange can be purchased as a stand-alone item under part number MU-075 (more details on page 15).

5. **"Hit and Hold" voltage reduction.** Within 100 ms of valve actuation, the voltage required to hold the valve in position can be reduced. The voltage step-down results in the dual benefits of power conservation and heat reduction. The amount of the voltage reduction possible is 66% (i.e. 24 Vdc to 8 Vdc or 12 Vdc to 4 Vdc) for all pinch valves that do not incorporate the "quiet" feature. This results in a power usage reduction of 89%, resulting in a correspondingly large drop in heat generation.

For the pinch valves with the "quiet" feature, voltage can be reduced by 50% (i.e. 24 Vdc to 12 Vdc and 12 Vdc to 6 Vdc) after 100 ms for a power usage drop of 75%.

This voltage reduction can be accomplished using the Bio-Chem Fluidics CoolCube™ hit-and-hold circuit (more details on page 14).

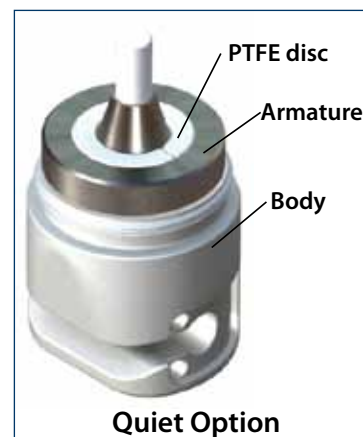

How it works: A PTFE disc is inserted between the internal components. The disc cushions the motion of the plunger, leading to a substantial reduction in noise.

OPTICAL POSITION FEEDBACK SENSOR

Position feedback is provided through a compact, factory-mounted infrared optical sensor that instantaneously detects the position of the pinch valve pusher/armature assembly. An electrical signal is transmitted back to the instrument control system, confirming whether the valve is open or closed. With no moving parts, the optical sensor has a virtually unlimited life. The position feedback sensor is an essential feature in many critical operations, such as in medical applications.

Availability:

075P2NC, 100P2NC, 075P3, 100P3 and 100PD valves

Electrical specifications:

Input voltage: 5.0 VDC
 Maximum output voltage: 30.0 VDC
 Maximum output current: 50.0 mA

Proper valve function is indicated by a drop in feedback voltage when the valve is open.

Typical set-up diagram:

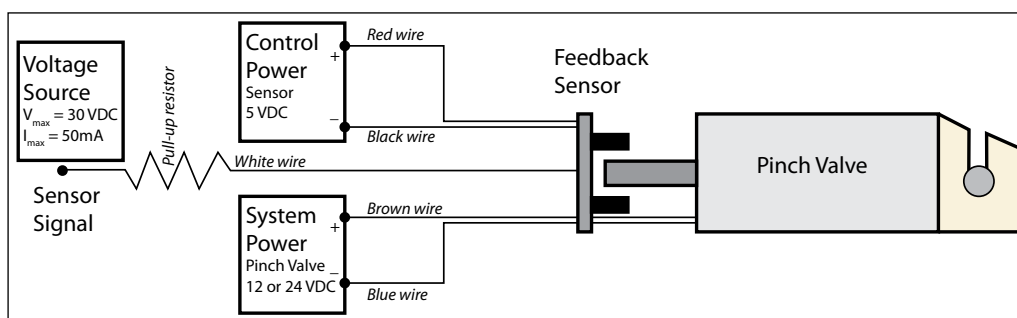

Feedback sensor mounted on 100P2NC valve

CoolCube™ "HIT AND HOLD" CIRCUIT

The CoolCube™ "Hit and Hold" circuit steps down DC voltage through Pulse Width Modulation after 100 ms. This reduces power consumption and heat generation while in "hold" setting and permits faster response and greater force through brief use of voltage above valve nominal rating. There is no power storage and the valve turns off immediately when power is cut to the circuit. The CoolCube™ includes terminal pins for easy in-line installation.

Availability:

CoolCube™ is available for ALL pinch valve configurations. 100PD range pinch valves, 108P range pinch valves and pinch valves with "quiet" option require the CoolCube-50R, otherwise select the CoolCube-R.

Specifications:

SERIES	COOLCUBE-R	COOLCUBE-50R
Time from "hit" to "hold" voltage:	100 ms	100 ms
Voltage step down percentage:	67%	50%
Max input voltage:	36 VDC	36 VDC
Max input current:	1 amp	1 amp
"Hold" voltage with 36 VDC input:	12 VDC	18 VDC
"Hold" voltage with 24 VDC input:	8 VDC	12 VDC
"Hold" voltage with 12 VDC input:	4 VDC	6 VDC
Power consumption reduction:	89%	75%

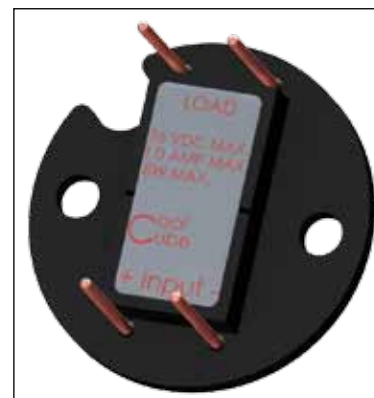

CoolCube™

MOUNTING OPTIONS

Bio-Chem Valve™ Pinch Valves are easy to mount using one of our stock mounting accessories. Three styles are offered to cover the vast majority of mounting needs. Mounting holes are also available as an option on most pinch valves (refer to page 13).

MU-series mounting flange:

- Constructed from sturdy, glass-filled Polypropylene
- Spring steel retainer and set screw ensure a secure fit
- Surface withstands alcohol, bleaches and other common cleaning agents
- Screw hole orientation relative to tubing can be adjusted to fit available system space



MR-series mounting rings:

- Constructed from Aluminum
- Set screw secures ring firmly to valve but can be loosened for re-positioning
- Can be bulkhead mounted, inside or outside
- Screw hole orientation relative to tubing can be adjusted to fit available system space



MC-series mounting clips:

- Constructed from Spring Steel
- Simple construction - no tools required to secure valve into position
- Holds valve securely inside instrument



PINCH VALVE CONNECTOR ACCESSORIES

Bio-Chem Valve™ Pinch Valves are designed to allow for fast and easy replacement of the tubing that makes up the fluid path through the valve. Inevitably the soft wall tubing has to interface with either other tubing or a threaded port. Bio-Chem Fluidics offers the following options to provide connectivity between the pinch valve and ancillary instrumentation and equipment.



DESCRIPTION	PART NO.
Y-con'r for 1/32" ID	Y-01P
Y-con'r for 1/16" ID	Y-02P
Y-con'r for 1/8" ID	Y-05P

Y-connectors

Use to split one soft wall tube into two streams or to combine two inputs into one output.

Polypropylene construction, three sizes available, pack size: 10



DESCRIPTION	PART NO.
Red'r for 1/16" ID to 1/32" ID	R-02/-01P
Red'r for 1/8" ID to 1/16" ID	R-05/-02P

Reducers

Use to connect two un-equal sized tubes.

Polypropylene construction, two sizes available, pack size: 10



DESCRIPTION	PART NO.
Con'r for 1/32" ID	S-01P
Con'r for 1/16" ID	S-02P
Con'r for 1/8" ID	S-05P

Straight connectors

Use to connect two equal sized tubes.

Polypropylene construction, three sizes available, pack size: 10



DESCRIPTION	PART NO.
1mm ID to 1/4"-28 th'd	008NB10-AD5B
1.5mm ID to 1/4"-28 th'd	008NB15-AD5B
3.2mm ID to 1/4"-28 th'd	008NB32-AD5B

Barbed Adaptors

Use to connect soft-walled tubing to threaded port.

Acetal construction, three sizes available, pack size: 5

THE ARCMED GROUP

Arcmed and its affiliates are dedicated to providing instrument manufacturers and laboratories with the industry's best choice of inert, miniature fluid handling components.

Under the Bio-Chem Fluidics brand name we offer a complete fluid system solution for a wide range of industries including analytical chemistry, clinical diagnostics and medical device manufacturers as well as the scientific community.

BIO-CHEM FLUIDICS

INERT SOLENOID VALVES AND PUMPS, ELECTRIC ROTARY VALVES

MICRO-PUMPS



ISOLATION VALVES



FLOW SELECTION VALVES

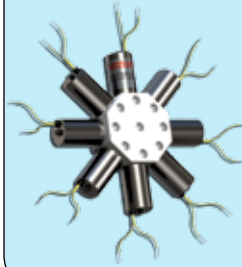

PINCH VALVES



ELECTRIC ROTARY VALVES



MANIFOLD ASSEMBLIES



ACCESSORIES



CUSTOMIZATION SERVICES



BIO-CHEM FLUIDICS

www.ArcmedGroup.com

Bio-Chem Fluidics Inc
85 Fulton Street, Boonton NJ 07005 USA
t: (973) 263 3001
e: Questions@ArcmedGroup.com